

# DETAIL SHEET

Figure II-4.2.8 Block and Gravel Filter

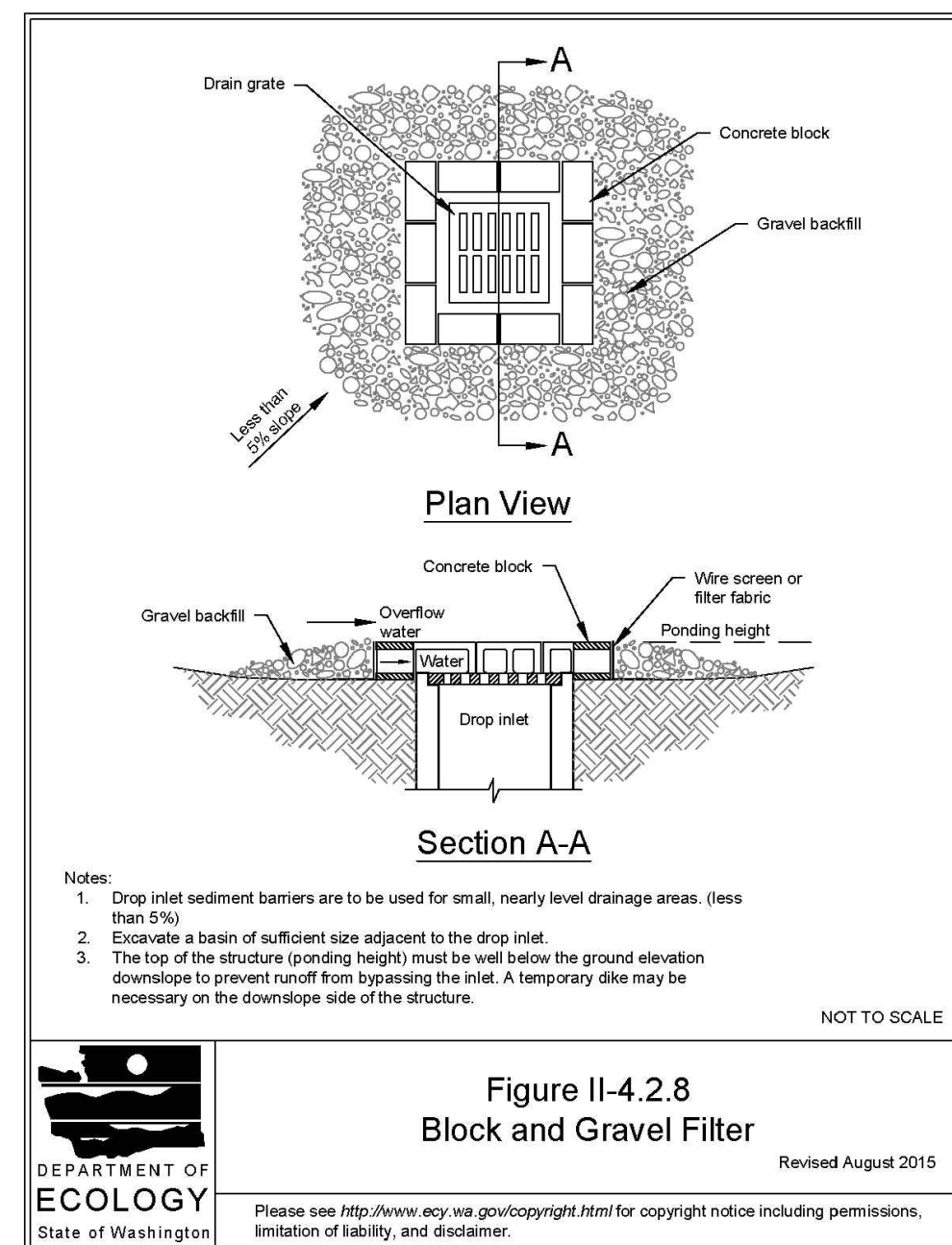
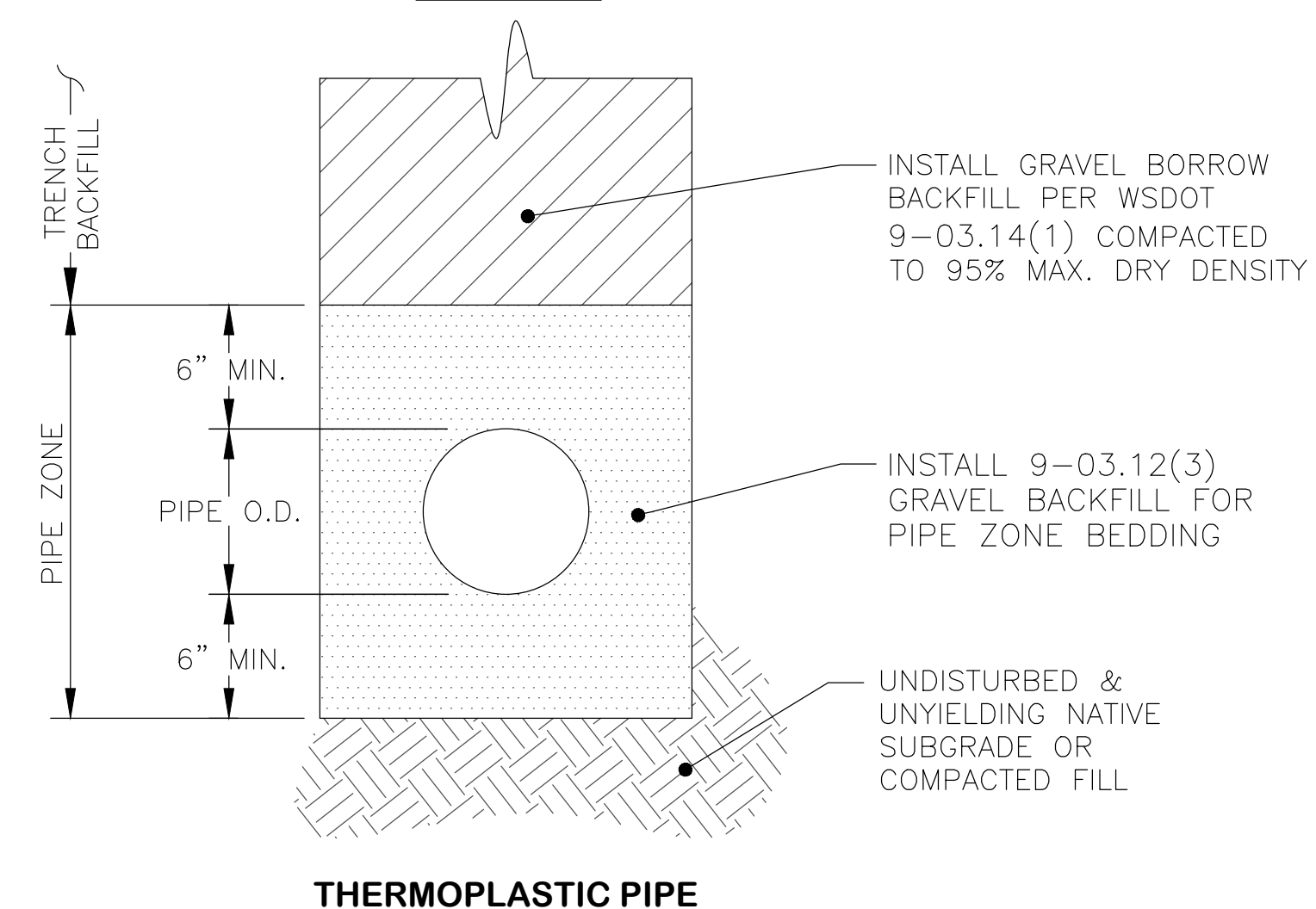
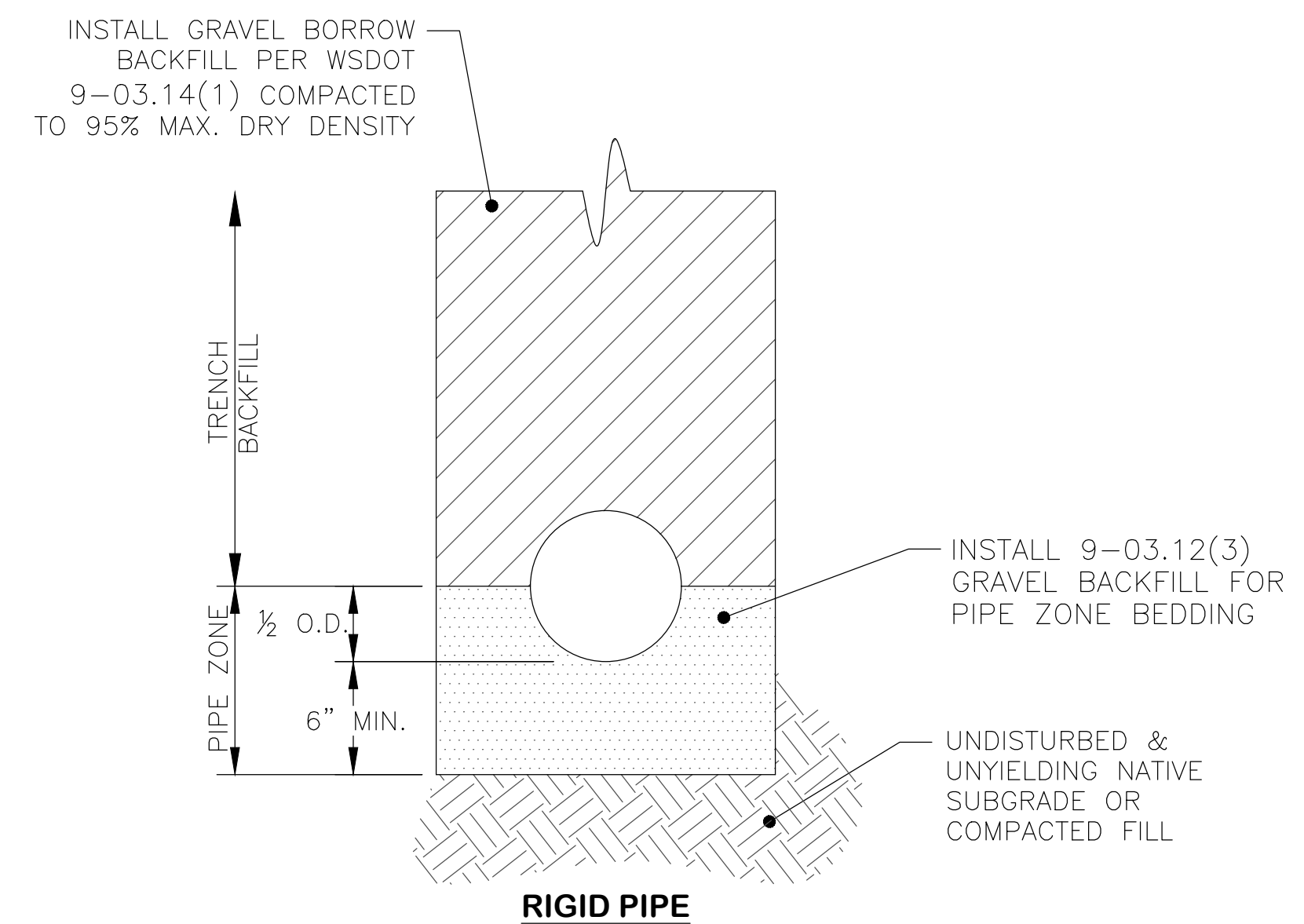
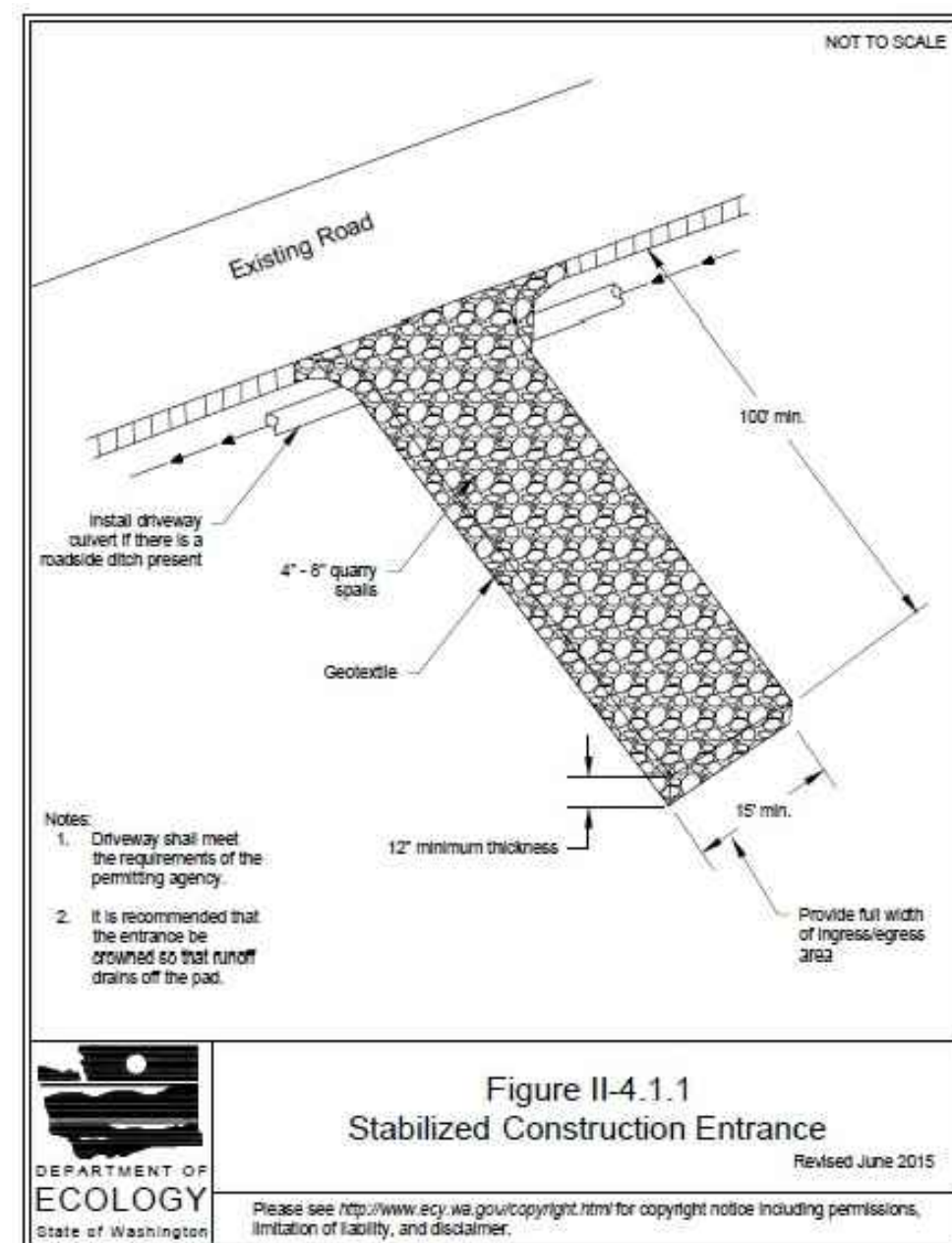
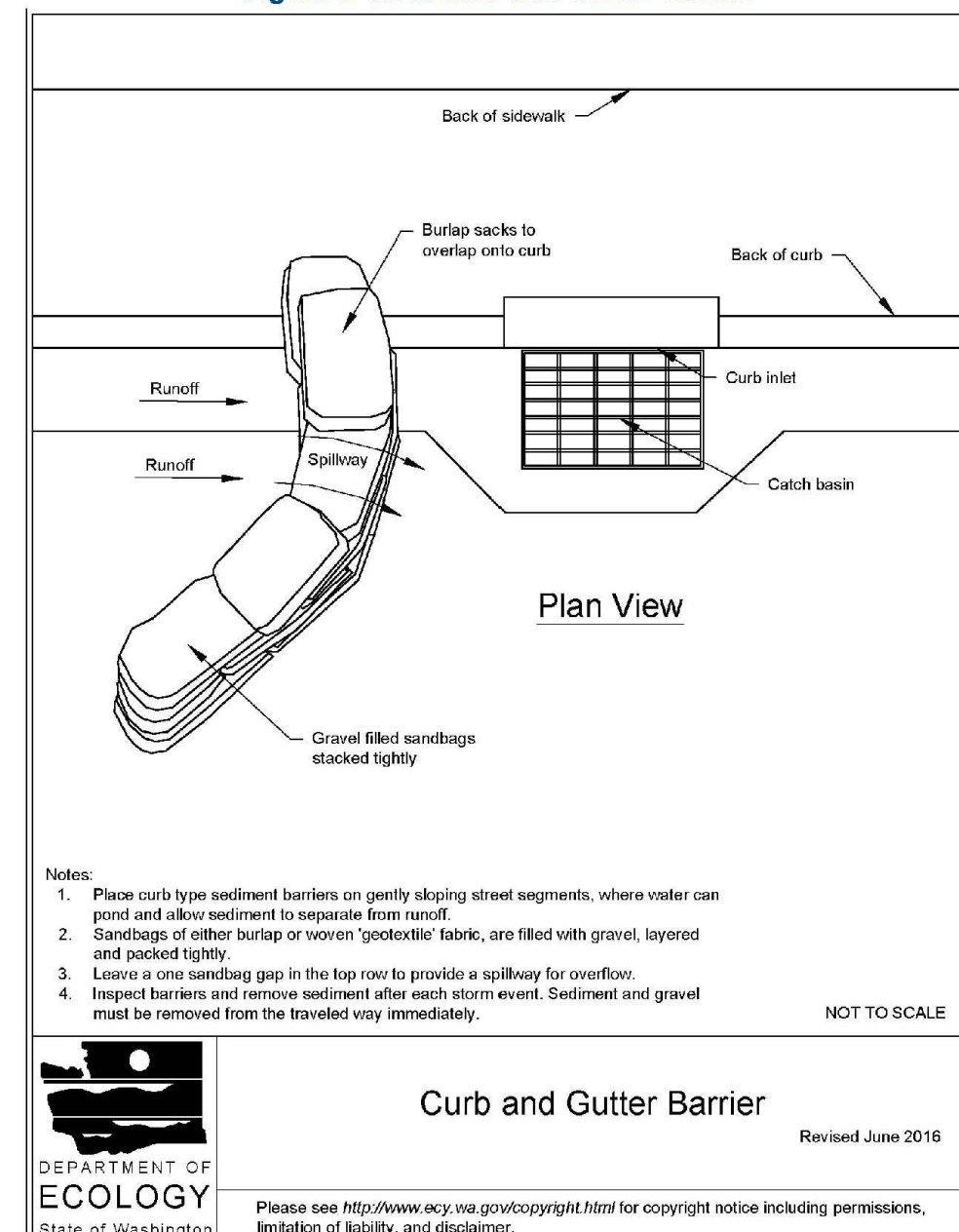
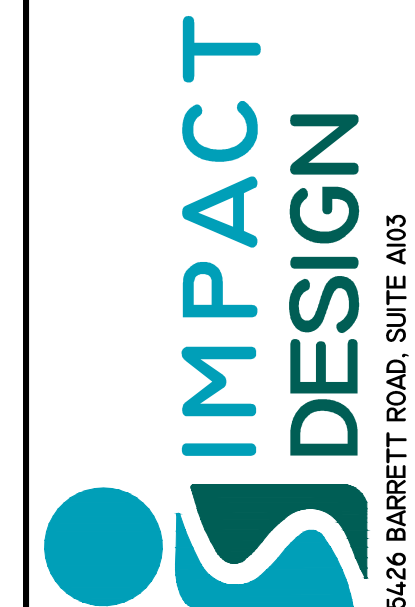
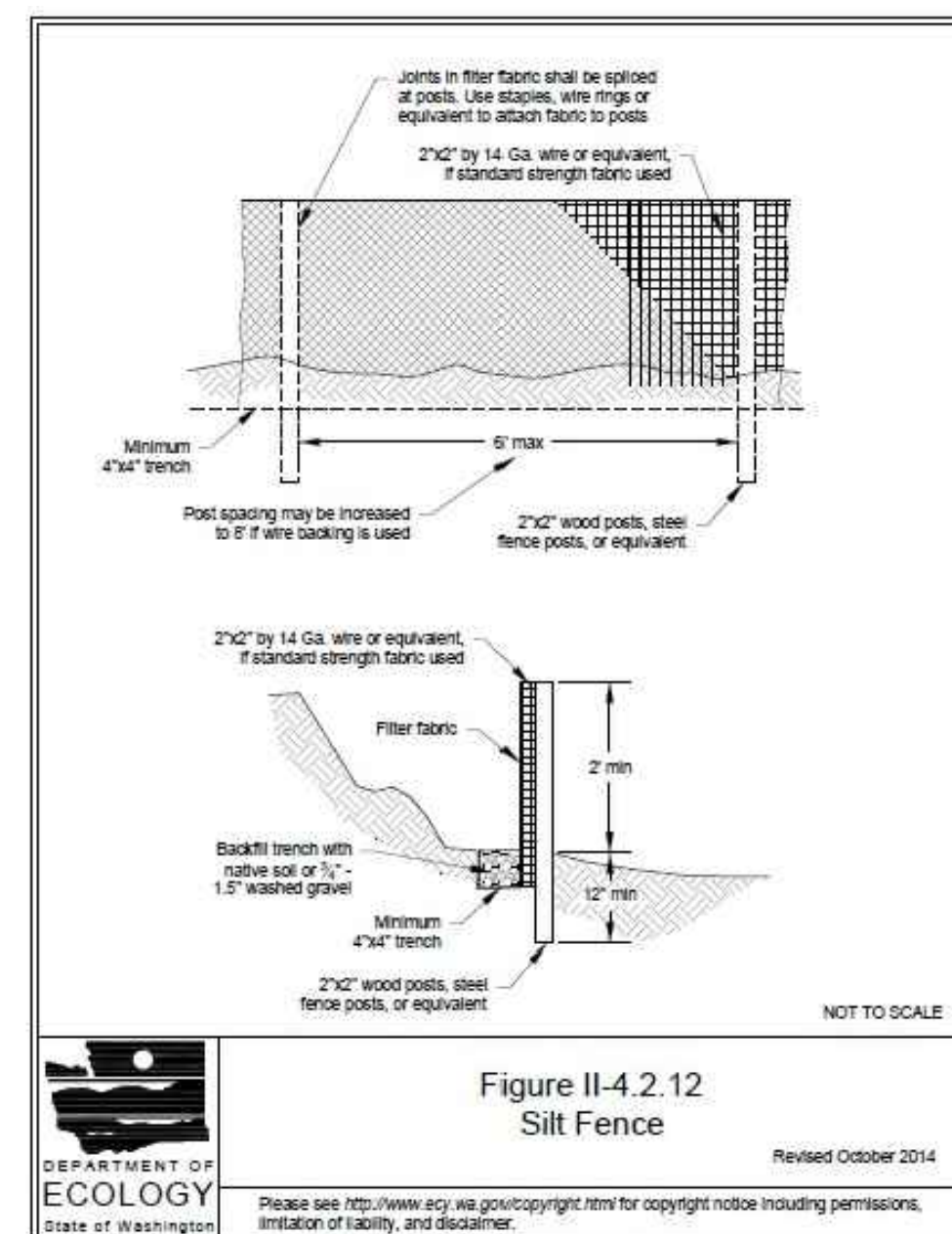
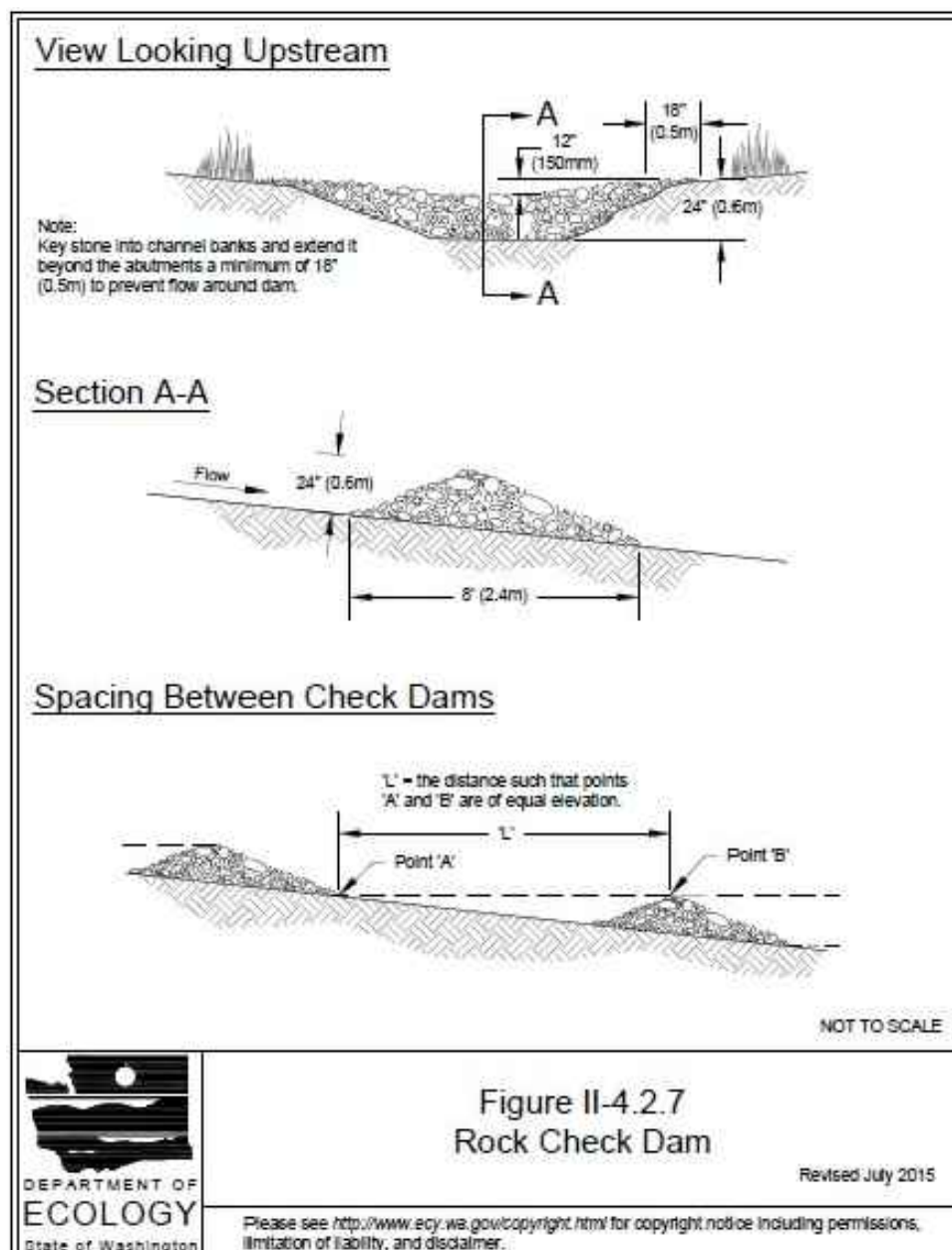

Figure II-3-19: Curb and Gutter Barrier



2014 Stormwater Management Manual for Western Washington  
Volume II - Chapter 4 - Page 360

2019 Stormwater Management Manual for Western Washington  
Volume II - Chapter 3 - Page 364



SUDDEN VALLEY  
CULVERT REPLACEMENTS 2021  
DETAILS  
WHATCOM COUNTY, WASHINGTON

REV	DATE	BY	DESCRIPTION

PROJECT NUMBER:  
19031

DESIGNED/DRAWN BY:  
SIG

CHECKED BY:  
SIG

ISSUE DATE:  
03.23.23

Z:\Shared\PROJECTS\19031 SUDDEN VALLEY MAINTENANCE PROJECTS\003\Construction Plans\SVA\_Construction\_Dwg\_3-10-23.dwg Mar 23, 2023 - 1:01pm

**DIVISION 7:  
DRAINAGE STRUCTURES, STORM SEWERS, SANITARY SEWERS, WATER  
MAINS, AND CONDUITS**

**7-02 CULVERTS**

**7-02.1 Description**

(\*\*\*\*\*)

Section 7-02.1 is supplemented with the following:

This Work consists of the design, construction and installation of a Reinforced Concrete Four-Sided Structure in accordance with the Plans, these Specifications, and the Standard Plans.

The contractor shall provide a structural design and calculations stamped and sealed by a civil engineer licensed in Washington State with a background in structural engineering. This design will be provided to the Contracting Agency (Sudden Valley Community Association) for review and approval.

**7-02.2 Materials**

(\*\*\*\*\*)

Section 7-02.2 is supplemented with the following:

Four-Sided Box	Concrete Class 4000, min.	9-01 and 9-03
----------------	---------------------------	---------------

**7-02.3(6)A1 Design Criteria**

The Contractor shall produce a structural design to meet the requirements of the Contractor Supplied Design method described in Section 6-20.3(1)A1 and Whatcom County Planning and Development Services. This design will be submitted for a building permit by the Contracting Agency.

(\*\*\*\*\*)

Section 7-02.3(6)A1 is supplemented with the following:

The following values shall be used for design:

Live Load	HL-93
Live Load Surcharge	250 psf

**7-02.4 Measurement**

(\*\*\*\*\*)

Section 7-02.4 is supplemented with the following:

No specific unit of measurement shall apply to the lump sum item for "Precast Reinf. Conc. Box Culvert"

**7-02.5            Payment**

(\*\*\*\*\*)

Section 7-02.5 is supplemented with the following:

Payment will be made in accordance with Section 1-04.1 of the WSDOT Standard Specifications for:

The lump sum contract price for “Precast Reinf. Conc. Box Culvert” shall be full pay for all costs of material, labor, tools, supplies and equipment necessary to fabricate, store, deliver the precast reinforced concrete box culvert and head walls. The bid price shall include but not be limited to all culvert shop drawing preparation; design calculations; concrete; steel reinforcing, and delivery of the box culvert and all other materials required for fully functional concrete box culverts.

**CONSTRUCTION CONTRACT**

This Construction Contract, including all appendices, (the "Contract") is made and entered into by and between Owner and Contractor on the date of the last signature below for the construction of the project described below.

**OWNER**

Owner's Name	Sudden Valley Community Association
Address	ATTN: General Manager 4 Clubhouse Circle Bellingham, WA 98229
Telephone Number	(360) 734-6490

**CONTRACTOR**

Contractor's Name	
Address	
Telephone Number	
Contractor's Authorized Representative	
Federal Identification Number	
Registration Number	
Washington UBI Number	

For and in consideration of the Contract Price noted below, subject to the terms and conditions contained herein, Contractor agrees to perform the following work (the "Work") in a timely and workmanlike manner, including supplying all necessary supervision, materials, equipment, supplies, and skilled and sufficient workforce to fully, completely, and faithfully comply with all the terms and conditions of this Contract.

1. **PROJECT.** The Project is described as follows:

**Project Name:** \_\_\_\_\_

**Project Location:** \_\_\_\_\_

\_\_\_\_\_

**2. WORK.** The Contractor agrees to perform the following Work in accordance with all applicable laws, codes, and industry standards to construct the Project as follows:

---

---

---

(Insert and list above a precise description of the Work covered by this Subcontract, referring to the numbers of drawings and pages and/or sections of specifications including any applicable addenda and/or alternates, etc.)

**3. CONTRACT DOCUMENTS.** In addition to this Contract and the enclosed Standard Contract General Conditions, the Contract Documents for this Contract consist of:

Description of Document	Date

Any conflicting provisions in the Construction Documents shall be interpreted harmoniously if possible or, in the event they cannot be reconciled, then they shall be interpreted in the manner most favorable to the Owner, and the interpretation shall be governed in the following priority:

- i. This Contract;
- ii. Any drawings and/or specifications provided by the Owner;
- iii. Any Change Orders executed by and between the Owner and Contractor after execution of this Contract; and
- iv. The Contractor's Proposal.

**4. CONTRACT PRICE.** The Owner shall pay the Contractor \$\_\_\_\_\_, plus Washington State sales tax, for all Work completed in conformance with this Contract and the Construction Documents.

**5. TIME OF PERFORMANCE.** The Contractor shall commence construction no later than \_\_\_\_\_ (the "Commencement Date"), and Contractor shall complete all Work within \_\_\_\_\_ days of the Commencement Date (the "Contract Time"). The parties agree that time is of the essence of this Contract and the Owner will suffer damage and be put to additional expenses in the event that the Contractor does not have the Work substantially complete by the end of the Contract Time.

(CHECK IF APPLICABLE) Because it is difficult to accurately compute the amount of such costs and damages, the Contractor hereby covenants and agrees to pay to the Owner liquidated damages of \$\_\_\_\_ per day for each day that expires after the time set forth above, which the Contractor and Owner agree reasonably approximates Owner's actual damages.

**6. INSURANCE.** Contractor shall purchase and maintain insurance in the following amounts on a per occurrence and aggregate basis naming the Owner as an additional insured by endorsement. All such insurance shall be primary to any coverage carried by Owner. Contractor shall provide Owner evidence of such coverage prior to commencing the Work.

	<b>Per Occurrence Coverage</b>	<b>Aggregate Coverage</b>
<b>General Commercial Liability</b>	\$1,000,000	\$2,000,000
<b>Automobile Liability</b>	\$250,000 or such higher amount as Contractor currently carries	NA

7. **GENERAL CONDITIONS.** The Standard Contract General Conditions (the "General Conditions") are attached hereto are incorporated herein by this reference.

8. **REPRESENTATIONS.** The Owner and the Contractor represent and warrant that the following statements are true and accurate:

***THIS CONTRACT CONTAINS AN INDEMNIFICATION OF CERTAIN LIABILITIES AND A WAIVER OF CONTRACTOR'S TITLE 51 RCW IMMUNITY.***

**IN WITNESS WHEREOF,** Owner and Contractor have executed this Contract, effective the date of the last authorized signature below.

**OWNER:**

**CONTRACTOR:**

SUDDEN VALLEY COMMUNITY  
ASSOCIATION

\_\_\_\_\_

\_\_\_\_\_

Date: \_\_\_\_\_

By: \_\_\_\_\_

Its: \_\_\_\_\_

Date: \_\_\_\_\_

## STANDARD CONTRACT GENERAL CONDITIONS

- A. Subcontractors and Lien Releases.** Contractor shall, upon request of Owner, provide a list of all subcontractors and suppliers of Contractor. Owner may request partial lien releases for all partial payments and a final lien release for the final payment to each subcontractor.
- B. Scheduling.** Owner shall give Contractor advance notice of anticipated starting date for Contract Work. Contractor shall start Work on the date agreed to by Owner and Contractor and shall complete the several portions and the whole of the Work herein described at such times as reasonably specified by the Owner in order to allow Owner to timely complete the Project. Contractor shall cooperate with Owner and other contractors hired by Owner to coordinate Work with other Contractors.
- C. Payment.** Contractor shall receive progress payments on a monthly basis for Work approved by Owner and all materials to be used on the Project which have been stored on site by Contractor. Contractor shall make applications for payment on a monthly basis by submitting a bill by the \_\_\_\_\_ day of the month (the fifth (5th) day of the month if not so stated). Applications for payment submitted by the Contractor shall indicate the percentage of completion of each portion of the Contractor's Work as of the end of the period covered by the application for payment. Contractor shall be paid for Work completed to date from Owner's last progress billing date. Owner shall withhold 5% retention from each progress payment. Retainage shall be paid within \_\_\_ days after the latest of the following: (i) Owner's approval of completion of the Work, (ii) close out of all paperwork required herein and (iii) receipt of required lien releases.

The Owner shall pay the approved amounts within \_\_\_\_\_ days (thirty (30) days if not so stated) of the date on which the application for payment is received.

Final payment for Work under this Contract shall be made within \_\_\_\_\_ days (thirty (30) days if not so stated) after Owner has approved the completion of the Work and Contractor has fulfilled each of its obligations under this Contract. As a prerequisite for any payment, Contractor shall provide, in a form satisfactory to Owner, partial lien releases, claim waivers and affidavits of payment from Contractor and its lower-tier subcontractors and suppliers of any tier, for the completed portions of Contractor's Work. Before issuance of the final payment, the Contractor shall submit evidence satisfactory to Owner that all payrolls, bills for materials and equipment, and all known indebtedness connected with the Contractor's Work have been satisfied. Contractor shall provide Owner with a signed lien release before receiving final payment.

Contractor shall be entitled to payment by Owner of all undisputed amounts. In the event that the Owner disputes an amount, the Owner may withhold fifty percent (50%) of the disputed amount. Owner shall provide a written explanation of the reason for the dispute with the payment.

Owner shall be entitled, but not required, to issue two-party checks in the name of the Contractor and any of Contractor's subcontractors or suppliers, union(s) for which Contractor's employees are members, any union trust fund, medical fund or pension fund for which Contractor's employees are members.

Contractor may invoice for materials delivered to the jobsite and receive payment as outlined above. Materials delivered to the site, and not installed, shall be paid at invoice cost. Contractor shall pay its own subcontractors and suppliers all sums owed them within ten (10)

days of receipt of payment from or on behalf of Owner. Contractor agrees that no assignment of any payment otherwise due under this Contract shall be effective without first securing the express approval of any assignee to the limitations contained in this subsection.

**D. Change Orders.** Owner may, without invalidating this Contract, order in writing extra Work or make changes by altering, adding to, or deducting from the Work and the Contract price and time shall be adjusted accordingly. All such Work shall be executed under the conditions hereof. All Change Orders shall be in writing and signed by the Owner and Contractor. The Owner shall not be liable for any additional Work performed by Contractor unless such additional Work has been incorporated into a Change Order. **NO ORAL INSTRUCTIONS AUTHORIZING A CHANGE IN THE WORK, ADJUSTMENT IN THE CONTRACT SUM, MAXIMUM CONTRACT SUM, OR ADJUSTMENT IN THE CONTRACT TIME SHALL BE VALID OR BINDING ON THE OWNER.**

If additional Work has been fully accepted by Owner, payment shall be made to Contractor with the next regular payment as provided herein. Contractor acknowledges that, unless expressly stated otherwise within a written Change Order, any change in the Contract Price and Time effected through a written Change Order shall constitute full and final payment and accord and satisfaction for any and all cost incurred (including, but not limited to, home office and field overhead and profit), labor performed, material and equipment furnished, and any delay, acceleration, or loss of efficiency associated with or arising out of the change in the Work.

**E. Nature of Work.** Contractor has conducted a full examination of all relevant plans and specifications and is not aware of any defects or mistakes in the applicable plans and specifications that would make the Work not buildable according to the applicable plans and specifications, for the Contract Price provided herein and in the time provided for herein. Contractor has satisfied itself as to the nature and location of the Work, the character, kind and quantity of material to be encountered, the character, kind and quantity of equipment needed, the location, conditions and other matters which can in any matter affect the Work under this Contract agreement and acknowledges that Contractor has had a reasonable opportunity to examine the site.

**F. Contractor Employer.** Contractor has the status of "employer" as defined by the Industrial Insurance, Workers' Compensation, Unemployment Compensation, Social Security, and other similar acts of the federal, state, and local government. Contractor shall withhold from its payroll applicable Social Security taxes, Workers' Compensation and Unemployment Compensation contributions and any other lawfully required withholding and pay the same; Owner shall be in no way liable as an employer of, or on account of, any employees of Contractor.

**G. Permits & Taxes.** Contractor shall obtain and pay for all permits, fees, and licenses necessary for the performance of this Contract and shall pay any and all federal, state, and local taxes, applicable to the Work to be performed under this Contract. Contractor shall also be responsible for payment of state sales/use taxes applicable to the Work of Contractor.

**H. Contractor Property.** Materials delivered by or for Contractor and intended to be incorporated into the construction hereunder shall remain on the jobsite and shall become property of Owner upon incorporation into the Work. Contractor may repossess any surplus materials remaining at the completion of the Contract; provided, Contractor shall not charge Owner for any repossessed materials. All scaffolding, apparatus, ways, works, tools, equipment, machinery, and plans brought upon the premises by Contractor shall remain

Contractor's property. It shall be Contractor's responsibility to unload, store, and protect its property to bear the risk of loss thereof.

Materials delivered by or for Contractor and intended to be incorporated into the construction hereunder shall remain on the site and shall become property of Owner upon incorporation into the Work, but Contractor may repossess any surplus materials remaining at the completion of the contract; provided, however, Contractor shall not charge Owner for any repossessed materials. All scaffolding, apparatus, ways, works, machinery, and plants brought upon the premises by Contractor shall remain Contractor's property. It shall be Contractor's responsibility to unload, store, and protect its materials, to bear the risk of loss thereof and to protect such material against loss until actually incorporated into the Work and until the Work is accepted.

**I. Default and Takeover.** Upon three (3) calendar days' written notice to Contractor, Owner may terminate this Contract in whole or in part for Owner's convenience and/or at its option. Contractor's remedy for such convenience or optional termination is limited to the following: (1) payment pursuant to the terms of this Contract for all Work properly performed prior to termination; (2) partial payment for lump sum items of Work on the basis of the percent complete of such items at the time of termination; and (3) Contractor's reasonable close-out costs. In no event shall Contractor be entitled to any compensation for loss of anticipated profits or unallocated overhead on Work not performed.

Contractor shall be in default of this Contract if it refuses or fails to supply enough properly-skilled workers or materials, refuses or fails to make prompt payment to subcontractors or suppliers of labor, materials or services, fails to correct, replace, or re-execute faulty or defective Work done or materials furnished, disregards the law, ordinances, rules, regulations or orders of any public authority having jurisdiction, files for bankruptcy, or materially breaches this Contract. If Contractor fails to correct the default and maintain the corrected condition within not less than three (3) working days of receipt of written notice of the default, then Owner, without prejudice to any rights or remedies otherwise available to it, shall have the right to terminate this Contract in writing and thereafter either perform the Work itself or obtain another Contractor to perform the Work. All of the costs incurred by Owner shall be charged to Contractor and Owner shall have the right to deduct such expenses from monies due or to become due Contractor. Contractor shall be liable for the payment of any expenses incurred by Owner in excess of the unpaid balance of the Contract Price.

In the event of an emergency including, but not limited to, the imminent potential damage to persons or property requires immediate repair Owner shall be entitled to conduct such repairs without providing advance written notice of the same to Contractor. Owner shall issue written notification to Contractor of such emergency repairs within five (5) days after making such repairs. Contractor shall be solely responsible for the cost of all such emergency repairs.

If Owner's termination for default is later deemed to be wrongful, without cause, or otherwise unjustified, the parties agree that the termination automatically converts to a termination for convenience and Contractor agrees that its remedies for such wrongful termination shall be limited to those provided in the termination for convenience.

If Contractor files or otherwise becomes subject to bankruptcy proceedings, Owner and Contractor agree that any delay attendant to the assumption or rejection of the Contract by the bankruptcy Trustee or a debtor-in-possession will be prejudicial to Owner. Consequently, Contractor, to minimize delay and to mitigate damages and/or other prejudice suffered by

Owner, hereby stipulates to a notice period of ten (10) calendar days for Owner's motion to require Trustee or debtor-in-possession to assume or reject the Contract.

**J. Unit Price.** In the event this Contract contains unit price items, it is understood and agreed that any quantities mentioned are approximations only and subject to change as required by the Contract or as ordered and directed by Owner.

**K. Material Quality.** Materials condemned by Owner as failing to conform to the Contract shall, upon notice from Owner, be immediately removed by Contractor. Failure of Owner to immediately condemn any Work or materials as installed shall not in any way waive Owner's right to object thereto to any subsequent time.

**L. Job Damage.** Damage caused by Contractor, its subcontractors or suppliers, or any subcontractor or supplier of any tier, to Work other than its own shall be reported immediately to Owner and Contractor shall be responsible for its repair. Damage caused by Owner to Work of Contractor shall be reported immediately to Contractor and Owner shall be responsible for its repair.

**M. Safety.** Contractor and its subcontractors shall take all reasonably necessary safety precautions pertaining to its Work and its Work performance, including compliance with applicable laws, ordinances, regulations and orders issued by a public authority, whether federal, state, local or other, OSHA (Federal Occupational Safety and Health Administration) / DOSH (Washington State Division of Occupational Safety and Health) / WISHA (Washington Industrial Safety and Health Act), and any safety measures requested by Contractor. Contractor shall at all times be responsible for providing a safe jobsite and be responsible for the Work performance and safety of all employees, personnel, equipment and materials within Contractor's or its subcontractors' care, custody or control. Contractor and its subcontractors shall furnish all required safety equipment for its Work and ensure all of their employees and subcontractors' employees have and wear personal protective equipment in compliance with applicable OSHA/DOSH/WISHA requirements.

Contractor certifies that it and its subcontractors are registered contractors. Contractor certifies that it and its subcontractors maintain a written Accident Prevention Plan and a Project-specific safety plan in compliance with applicable OSHA/DOSH/WISHA regulations. Contractor's Accident Prevention Plan should address subcontractor's role and responsibilities pertaining to safety on the Project, training and corrective action and be tailored to safety and health requirements for the Work involved. Contractor shall have and enforce a disciplinary action schedule in the event safety violations are discovered. When and as requested by Owner, Contractor shall provide information regarding safety matters.

Contractor shall promptly provide Owner with written notice of safety hazard(s) or violation(s) found on the Project or of any injury to its or its subcontractors' workers incurred on the Project.

Contractor agrees to defend, indemnify and hold Owner harmless from all OSHA/DOSH/WISHA claims, demands, proceedings, violations, penalties, assessments or fines that arise out of or relate to Contractor's failure to comply with any safety-related laws, ordinances, rules, regulations, orders or its obligations hereunder. Owner may charge against the sums otherwise owing to Contractor the Amount of the fine and the fees, costs and expenses incurred by Owner in the defense of the claims, citation and/or fine arising from or relating to the Contractor's above-referenced failure.

**N. Housekeeping and Cleanup.** Contractor shall regularly remove all refuse, waste and debris produced by its operation. Refuse shall not be permitted to accumulate to the extent that it interferes with free access to the Project or creates a safety hazard. Avoidance of safety hazards through good housekeeping is an important part of Contractor's obligations. In the event Contractor or its subcontractor fails or refuses to meet these requirements, Owner may remove refuse and charge all costs to the Subcontract, provided that Contractor has received twenty-four (24) hours or one (1) full working day, whichever is greater, prior written notice. In the event Owner determines emergency conditions exist, Owner may proceed as above without prior notice.

Contractor shall comply with all applicable hazardous waste regulations under federal, state or local laws. Contractor shall provide Owner with all Safety Data Sheets ("SDS") for any and all hazardous substances covered under all applicable laws before commencing Work, and all SDS shall comply with OSHA's Hazard Communication Standard. Contractor shall, prior to commencing Work, inform Owner of its intent to use any hazardous substances at the Project and shall continuously update Owner of any new hazardous substance brought to the Project during performance of the Work. Failure to comply with this paragraph may result in fines and damages being assessed to Contractor. Contractor shall defend, indemnify and hold Owner harmless from any and all costs and expenses, including attorneys' fees, arising from the use or discharge of any hazardous substance by Contractor at or off the Project site.

**O. Release and Hold Harmless – Damage to Equipment.** Contractor hereby releases, discharges and agrees to hold Owner harmless from any damage either to the Contractor's property or rented equipment which is caused in whole or in part by the negligence of Contractor, its agents, employees or subcontractors.

**P. Insurance.** Contractor shall obtain and keep in force during the term of this Contract and the applicable Statutes of Repose and Limitations period, commercial general liability insurance with dollar limits and coverage equal to, or greater than the types and amounts of coverage noted at the front of this Contract. Such insurance shall be "occurrence-based" and shall include contractual liability coverage applicable to the indemnity provisions of this Contract and "completed operations" coverage. Contractor shall furnish to Owner evidence of this insurance including the provision regarding notice of cancellation or reduction in coverage. Such evidence of insurance shall be in the form of an Insurance Certificate issued by an insurer satisfactory to Owner and shall provide for not less than thirty (30) days prior written notice to Owner of cancellation or reduction in coverage. In the event Contractor fails to maintain any and all insurance required by this Contract during the entire life of this Contract, Owner may at its option, and without waiver of other available remedies, purchase such insurance in the name of Contractor and deduct the cost of same from payments due Contractor.

Contractor shall provide insurance that: (1) names Owner as an additional insured for liability arising out of the Contractor's Work, including completed operations losses, without qualification, limitation or reservation; (2) is endorsed to be primary and noncontributory with any insurance maintained by Owner; (3) does not contain a "cross liability" or similar exclusion that would bar coverage for claims between or among insureds; (4) contains a severability of interest provision in favor of Owner; and (5) contains a waiver of subrogation against Owner. Before commencing work, Contractor shall provide a copy of the additional insured endorsement to Owner as evidence of additional insured status.

Owner makes no representations that the required minimum amount of insurance is adequate to protect Contractor. The procuring and/or carrying of insurance shall not limit Contractor's obligation or liability pursuant to this Contract or as a matter of law.

**Q. Workers' Compensation.** Contractor shall furnish to Owner evidence that its workers are covered by applicable workers' compensation coverage.

**R. Subcontractors.** Contractor shall, upon request of Owner, provide a list of all subcontractors and suppliers of Contractor. With regard to all subcontractors retained by the Contractor, the Contractor agrees (i) to be primarily responsible for any Work performed by such subcontractor and to ensure that such Work is timely completed in the manner required herein; (ii) to ensure that invoices submitted by subcontractor comply with the requirements for invoices submitted by Contractor to Owner; (iii) that Contractor shall be solely responsible to make any necessary repairs or to perform punch-list items caused by subcontractor's Work; and (iv) to ensure that subcontractor complies with all the obligations of Contractor set forth herein and to be primarily responsible for any non-compliance. Contractor shall be solely responsible for paying subcontractor any amounts due to it. Owner may request partial lien releases for all partial payments and a final lien release for the final payment to each subcontractor. Contractor agrees to release Owner and to hold Owner harmless from any and all claims by subcontractor for payment.

**S. Disputes and Back Charges.** In the event of a dispute between Owner and Contractor, Contractor agrees to proceed with the Work in accordance with the requirements of this Contract, pending settlement of the dispute.

**T. Indemnification.** To the fullest extent permitted by law, the Contractor shall defend, indemnify and hold harmless the Owner and its agents and employees from and against claims, damages, losses and expenses, including, but not limited to attorneys' and expert's fees, (collectively a "claim") arising out of or resulting from performance of the Contractor's Work under this Contract. Such obligation shall not be construed to negate, abridge, or otherwise reduce other rights or obligations of indemnity which would otherwise exist as to a party or person described in this paragraph.

Contractor's duty to indemnify Owner shall not apply to liability for damages arising out of claims caused by or resulting in whole from the negligence of Owner or its agents or employees. Contractor's duty to indemnify Owner for liability for damages arising out of claims caused by or resulting from the concurrent negligence of: (a) Owner, its agents or employees, and (b) Contractor, its agents, employees and lower-tier subcontractors or suppliers of any tier shall apply only to the extent of negligence of Contractor, its agents, employees and lower-tier subcontractors or supplier of any tier.

**CONTRACTOR SPECIFICALLY AND EXPRESSLY WAIVES ANY IMMUNITY THAT MAY BE GRANTED IT UNDER THE WASHINGTON STATE INDUSTRIAL INSURANCE ACT, TITLE 51 RCW. FURTHER, THE INDEMNIFICATION OBLIGATION UNDER THIS CONTRACT SHALL NOT BE LIMITED IN ANY WAY BY ANY LIMITATION ON THE AMOUNT OR TYPE OF DAMAGES, COMPENSATION OR BENEFITS PAYABLE TO OR FOR ANY THIRD PARTY UNDER WORKERS' COMPENSATION ACTS, DISABILITY BENEFITS ACTS, OR OTHER EMPLOYEE BENEFITS ACTS PROVIDED CONTRACTOR'S WAIVER OF IMMUNITY BY THE PROVISIONS OF THIS PARAGRAPH EXTENDS ONLY TO CLAIMS AGAINST CONTRACTOR BY OWNER, AND DOES NOT INCLUDE, OR EXTEND TO, ANY CLAIMS BY CONTRACTOR'S EMPLOYEES DIRECTLY AGAINST CONTRACTOR.**

Contractor's Initials \_\_\_\_\_

Contractor agrees that its defense and indemnity obligations to Owner under this Contract survive any limitation imposed by any statute of repose or limitation including but not limited to RCW 4.16.300, 4.16.310, or 4.16.326, and Contractor hereby waives any and all defenses under any statute of repose or limitations. Contractor further agrees that any statute of limitation on a claim by Owner pursuant to this provision shall not begin to run until Owner discovers that Contract has breached either its duty to defend or its duty to indemnify, whichever occurs first.

**U. Warranty.** The Contractor warrants to the Owner that materials and equipment furnished under the Contract will be of good quality and new, unless otherwise required or permitted by the Contract, that the Work of this Contract will be performed in a workmanlike manner and free from defects not inherent in the quality required or permitted, will comply with all applicable codes and regulations, will be consistent with industry standards, and that the Work will conform to the requirements of the Contract. This warranty shall be in addition to and not in limitation of any other warranty or remedy required by law or the Contract. This warranty shall extend for the longer of the period of (i) the warranty normally given by Contractor for the Work in its ordinary course of business, (ii) the warranty period set forth in the Quote or other documents sent to Owner, or (iii) one (1) year from the date of substantial completion of the Work or occupancy of the Project by Owner, whichever occurs first. The warranty shall not apply to any damage or loss to the Work occasioned by Owner's failure to perform ordinary and reasonable maintenance during the warranty period or any written notice of defects received after the one (1) year period. Owner shall promptly notify Contractor in writing of all warranty claims and allow Contractor reasonable access to the Project to correct or repair the Work.

**V. Contract Controls.** Except for the Scope of Work and Warranty provisions specifically incorporated herein by the Contract, any terms or conditions attached to or incorporated into Contractor's proposal, quote, or other document shall not apply to the Contract. The Contract shall be solely and exclusively governed by the terms and conditions set forth in the Contract and these Standard Contract General Conditions.

**W. Wage and Other Payments.** Contractor shall comply with all state and federal wage laws and, upon request, provide proof of the same to Owner. In addition, if Contractor's employees are members of a union, then Contractor shall pay when due all obligations due under the collective bargaining agreement or other agreement, including but not limited to, medical benefits, dental benefits, pension benefits and the like.

**X. Notices.** All notices, demands, requests, consents and approvals which may or are required to be given by any party to any other party hereunder shall be in writing and shall be deemed to have been duly given if delivered personally, sent by facsimile, emailed, sent by a nationally recognized overnight delivery service, or if mailed or deposited in the United States mail and sent by registered or certified mail, return receipt requested, postage prepaid to the address provided in this Contract or to such other address as either party hereto may from time-to-time designate in writing and deliver in a like manner. All notices shall be deemed complete upon actual receipt or refusal to accept delivery. Electronic transmission of any signed original document and retransmission of any signed electronic transmission shall be the same as delivery of an original document.

**Y. Claims.** As a condition precedent to any right to recover for any instances of interruption, disruption, extra work, additional work, changed work, delay, hindrance and/or

efficiency loss of any nature whatsoever in Contractor's Work (collectively "Impact"), believed by Contractor to be caused by the acts or omissions of Owner, Architect/Engineer or the employees or agents of any of them, Contractor must provide written notice to Owner in the manner required by this Contract within five (5) days after occurrence of the Impact. Such written notice shall identify the cause of the Impact, the party Contractor believes is responsible for the Impact, and a rough order of magnitude as to the extra cost and/or time resulting from the Impact. FAILURE OF CONTRACTOR TO PROVIDE TIMELY WRITTEN NOTICE, AS PROVIDED IN THIS PARAGRAPH, SHALL RESULT IN AN ABSOLUTE WAIVER AND FORFEITURE OF CONTRACTOR'S RIGHT TO RECOVER ANY ADDITIONAL COST OR TIME RESULTING FROM THE IMPACT.

In the event Contractor believes it is entitled to receive compensation and/or time due to damages from Impact(s), Contractor's Statement of Claim (setting forth in detail the entitlement and quantum basis for Contractor's claim with supporting data and/or the entitlement basis to support an extension of time) shall be delivered to Owner within fifteen (15) days of its Written Notice of Impact, or within sufficient time to allow Owner to comply with the notice and claim requirements of the Main Contract (whichever is sooner). FAILURE OF CONTRACTOR TO TIMELY PROVIDE ITS STATEMENT OF CLAIM FOR AN INCREASE IN THE CONTRACT AMOUNT OR FOR AN EXTENSION OF TIME SHALL RESULT IN AN ABSOLUTE WAIVER OF CONTRACTOR'S CLAIM AND ANY RIGHT TO RECOVER ADDITIONAL COST OR TIME RESULTING FROM THE IMPACT.

Owner does not waive the requirement for timely written notice and/or timely written submission of the Statement of Claim unless Owner's waiver is unequivocal, explicit, and in writing.

**Z. Mediation.** Claims, disputes, or other matters in controversy arising out of or related to this Contract, except those waived, shall be subject to mediation as a condition precedent to the institution of legal or equitable proceedings by either party. This requirement may be waived by Owner.

**AA. Arbitration / Litigation.** At Owner's sole option, all claims, disputes, and other matters in question between Contractor and Owner arising out of, or relating to, this Agreement shall be decided by arbitration in accordance with the Construction Industry Arbitration Rules of the American Arbitration Association then obtaining or by an arbitrator mutually agreed upon by the parties. In the event of arbitration, Contractor and Owner agree to be bound by the findings and award of such arbitration finally and without recourse to any court of law other than for the enforcement of the arbitrator's decision. If the Owner does not select Arbitration as the means of dispute resolution, all claims, disputes and other matters in question between Contractor and Owner arising out of, or relating to, this Agreement shall be decided by an action filed exclusively in the Superior Court of Whatcom County, Washington. The substantially prevailing party in any arbitration or litigation shall be entitled to an award of its attorneys' fees, costs and expert fees.

**BB. Governing Law.** This Agreement and the right of the parties hereto shall be governed by and construed in accordance with the laws of the State of Washington and the parties agree that in any such action venue shall lie exclusively in Whatcom County, Washington, regardless of where the Project is located. Both parties expressly waive their right to a jury trial.

**CC. Amendment.** No modification, termination or amendment of this Contract may be made except by written Contract signed by all parties.

**DD. Waiver.** Failure by Owner or Contractor to insist upon the strict performance of any covenant, duty agreement, or condition of this Contract or to exercise any right or remedy consequent upon a breach thereof shall not constitute a waiver of any such breach or any other covenant, agreement, term or condition. Any waiver must be expressly made in writing and signed by the waiving party.

**EE. Severability.** In case any one or more of the provisions contained in this Agreement shall, for any reason, be held to be invalid, illegal or unenforceable in any respect, such invalidity, illegality or unenforceability shall not affect any other provision hereof, and this Agreement shall be construed as if such invalid, illegal or unenforceable provision had never been contained herein.

**FF. Neutral Authorship.** Each of the provisions of this Agreement has been reviewed and negotiated, and represents the combined work product of both parties hereto. No presumption which would interpret the provisions of this Agreement in favor of or against the party preparing the same shall be applicable in connection with the construction or interpretation of any of the provisions of this Agreement.

**GG. Captions.** The captions of this Contract are for convenience and reference only and in no way define, limit, or describe the scope or intent of this Contract.

**HH. Entire Agreement.** The entire agreement between the parties hereto is contained in this Agreement; and this Agreement supersedes all of their previous understandings and agreements, written and oral, with respect to this transaction, including any proposal for services. Owner shall not be liable to Contractor or to any third party for any representations, made by any person, concerning the Work or the terms of this Agreement, except to the extent that the same are expressed in this Agreement. No modification, termination or amendment of this Agreement may be made except by written agreement signed by both parties.



# Sudden Valley Community Association

360-734-6430

4 Clubhouse Circle Bellingham, WA 98229

[www.suddenvalley.com](http://www.suddenvalley.com)

## CAPITAL REQUEST MEMO

**To:** Sudden Valley Community Association Finance Committee  
**From:** Glenn Akramoff, Interim General Manager  
**Date:** May 27, 2021  
**Subject:** Capital Request – 2021 Roads -Stormwater Culvert Replacement

---

**Purpose** – Request for capital funding for stormwater culvert replacement of culvert 182 and 315 from the road's capital fund.

**Background** – The Stormwater system is aging, and multiple culvert crossings have been identified as needing repair and replacement. There has been many identified as high priority. In 2020 several replacements were designed but not competed due to varying reasons, including cost. The Interim General Manager and Project Manager from PNW reviewed the 2020 list and the perspective 2021 list and decide that culvert 182 and 315 where the best candidates and best fit together for mobilizing a contractor.

**Analysis** –. The two culverts that have been identified have had design work completed and are permitted through the county at this time. Culvert 315 is also in review with the Lake Whatcom Water and Sewer District as those utilities will require minor relocation to replace the culvert. It is planned to have a contractor complete the work within the 2021 season. The work needs to be scheduled in the summer months because of material and contractor availability as well as the construction window. The engineering estimates of costs are attached.

**Proposal** – Provide funding for the replacement of Culvert 182 and 315 within the 2021 construction window.

**Request** – They are as follows:

Request **\$15,125.33** of the replacement of culvert 182 for the road's capital funds

Request **\$314,700.46** of the replacement of culvert 315 for the road's capital funds

The Roads Capital fund has approximately \$2,038,741 available of unallocated funds This amount also takes into account the latest 2021 CVC project obligation of \$182,258 and the board recommended carryover balance of \$500,000.



# Sudden Valley Community Association

360-734-6430

4 Clubhouse Circle Bellingham, WA 98229

[www.suddenvalley.com](http://www.suddenvalley.com)

## Approval:

Approved:  Not Approved:  Finance Committee

Approved:  Not Approved:  SVCA Board of Directors

## Motion:

I move to approve Stormwater Culvert 182 in the amount of **\$15,125.33** and Culvert 315 in the amount of **\$314,700.46** for repairs in 2021.



March 18, 2021

Sudden Valley Community Association  
Attn: General Manager  
4 Clubhouse Circle  
Bellingham, WA 98229

RE: Project Scope Letter – Culver 182 Replacement

PNW is providing this overall project scope letter to SVCA for replacing Culvert 182 proposed for replacement in 2021. The estimate below is for design, permitting, and construction costs anticipated. The construction costs are preliminary until design is complete.

<b>Culvert 182 – Design Estimate</b>	
- Impact Design – Site plan and Notice of Activity application.	\$1,500.00
- PNW Services, Inc. – Design Management, Permitting, Contractor Bids	\$945.00
- Permit Fee Allowance	\$500.00
Subtotal Design	\$2,945.00
Contingency at 10%	\$294.50
<b>Total Design Estimate with Contingency</b>	<b>\$3,239.50</b>
<b>Culvert 182 – Construction Estimate</b>	
- Impact Design – Engineers Estimate	\$12,130.30
- PNW Services, Inc. – Construction Management	\$1,620.00
Subtotal Construction	\$13,750.30
Contingency at 10%	\$1,375.03
<b>Total Construction Estimate with Contingency</b>	<b>\$15,125.33</b>

The design/permitting is minimal due to the fact that SVCA has the Programmatic Permit with Whatcom County that this culvert replacement should fall under.

Please let me know if you have any questions, or if you would like any further information.

Sincerely,

Tyler Andrews  
President

## 2021 Sudden Valley Culvert Replacements - Culvert 182 (Lost Fork Ln)

### Engineer's Estimate

December 3, 2020



Estimate Prepared by:  
**Impact Design, LLC**  
 5426 Barrett Road, Suite A103  
 Ferndale, WA 98248  
 Phone: (360) 389-8138

Client:  
**Tyler Andrews**  
**PNW Civil, Inc.**  
 PO Box 30498  
 Bellingham, WA 98228

		ESTIMATED CONSTRUCTION COST			
NO.	ITEM	QUANTITY	UNIT	UNIT COST	TOTAL
<b>CONSTRUCTION COSTS</b>					
1	MOBILIZATION	1	LS	\$2,000.00	\$2,000.00
2	PROJECT TEMPORARY TRAFFIC CONTROL	1	LS	\$1,000.00	\$1,000.00
3	CLEARING AND GRUBBING	1	L.S.	\$500.00	\$500.00
4	REMOVAL OF STRUCTURE AND OBSTRUCTION	1	L.S.	\$500.00	\$500.00
5	STRUCTURE EXCAVATION CLASS 'A'	15	C.Y.	\$18.00	\$270.00
6	GRAVEL BACKFILL FOR PIPE BEDDING	15	TON	\$30.00	\$450.00
7	CRUSHED SURFACING TOP COURSE	20	TON	\$30.00	\$600.00
8	CORRUGATED POLYETHYLENE STORM SEWER PIPE, 15-INCH DIAMETER	32	L.F.	\$85.00	\$2,720.00
9	DITCHING AND RESTORATION	50	L.F.	\$40.00	\$2,000.00
10	QUARRY SPALLS	2	TON	\$70.00	\$140.00
11	TEMPORARY EROSION AND SEDIMENT CONTROL	1	L.S.	\$1,000.00	\$1,000.00
<i>Subtotal</i>					<i>\$11,180.00</i>
<i>Tax @ 8.5%</i>					<i>\$950.30</i>
<i>Construction Cost Total</i>					<i>\$12,130.30</i>
<b>DESIGN COSTS</b>					
1	NOTICE OF ACTIVITY to WHATCOM COUNTY	1	LS	\$1,500.00	\$1,500.00
<i>Subtotal</i>					<i>\$1,500.00</i>
<i>10% Contingency (Construction and Design)</i>					<i>\$1,363.03</i>
<b>PROJECT TOTAL</b>					<b>\$14,993.33</b>

Assumes that County will not require a LDP, Critical Areas Report, SEPA Checklist, HPA or JARPA Permit Applications



12-3-2020

Sudden Valley Community Association

**2021 Culvert Replacements**

PNW Estimate - Bid Package, Permitting, and Construction Management

**Culvert 182 - Design Management**

Task	Description	Hours	Estimated Cost
Design Oversight	Site visit reviewing scope of work with engineer for site plan development, and completing the NOA application to Whatcom County.	1	
	<b>Total Estimated Design Oversight Hours</b>	1	<b>\$ 135.00</b>
Permitting	Review applications prepared by Engineering Team, facilitate SVCA permit application signature, and submit to Whatcom County.	1	
	Facilitate any permit questions by Whatcom County, and review issued permit.	1	
	Total Estimated Permitting Hours	2	\$ 270.00
	<b>Total Estimated Permitting Cost</b>		<b>\$ 270.00</b>
Contractor Bids	Prepare bid package, issue to contractors, and answer any bid questions.	3	
	Review construction bids, and provide recommendation to SVCA.	1	
	Total Estimated Bid Package Hours	4	\$ 540.00
	<b>Total Estimated Design Management Cost</b>		<b>\$ 945.00</b>

**Culvert 182 - Construction Management**

Task	Description	Hours	Estimated Cost
Construction Management	Contract issuance to contractor, and preconstruction coordination.	2	
	Construction observation	8	
	Construction closeout	2	
	<b>Total Estimated Construction Management Hours</b>	12	<b>\$ 1,620.00</b>
	<b>Total Estimated Design &amp; Construction Management Cost</b>		<b>\$ 2,565.00</b>



March 18, 2021

Sudden Valley Community Association  
Attn: General Manager  
4 Clubhouse Circle  
Bellingham, WA 98229

RE: Project Scope Letter – Culvert 315 Replacement

PNW is providing this overall project scope letter to SVCA for construction of Culvert 315 proposed to be replaced in 2021. Design and permitting is primarily complete.

<b>Culvert 315 – Construction Estimate</b>	
- Impact Design – Engineers Estimate	\$227,139.33
- LWWSW Sewer & Water Design Fee Allowance	\$26,212.00
- Geotest Allowance	\$6,000.00
- Utility Companies Allowance	\$10,000.00
- PNW Services, Inc. – Construction Management	\$16,740.00
Subtotal Construction	286,091.33
Contingency at 10%	28,609.13
<b>Total Construction Estimate with Contingency</b>	<b>314,700.46</b>

The capital improvement budget assumed replacement of the existing culvert with a RCP elliptical pipe; however, due to utility conflicts this method of replacement is not feasible. A concrete box culvert was the allowable fish passage replacement that WDFW would agree too that worked with site constraints. In addition, the capital improvement plan doesn’t mention needing to relocate the existing waterline or replace the existing sewer line under the culvert. Both are required and those costs are included in the updated Engineers Estimate, and the additional fee anticipated from LWWSW is also included above. These differences are believed to account for the estimated construction cost difference.

PSE has a 6” feeder line under the culvert that this estimate assumes can remain where it is, and a custom block out in the box culvert will be installed to maintain 6” clearance above the feeder line. This approach has been approved by WDFW, but is not officially approved by PSE. If relocation of the feeder line is required a substantial additional cost is expected of more than \$100,000. PNW has been working with PSE for months to get this finalized, and is waiting for final verification.

Please let me know if you have any questions, or if you would like any further information.

Sincerely,

Tyler Andrews  
President

P O B o x 3 0 4 9 8 • B e l l i n g h a m , W A 9 8 2 2 8 • p : 4 2 5 - 9 5 4 - 9 6 1 4

**2021 Sudden Valley Culvert Replacements - Culvert 315 (Polo Park Dr)**

Engineer's Estimate

December 15, 2020



Estimate Prepared by:  
**Impact Design, LLC**  
 5426 Barrett Road, Suite A103  
 Ferndale, WA 98248

Client:  
 Tyler Andrews  
 PNW Civil, Inc.  
 PO Box 30498  
 Bellingham, WA 98228

NO.	ITEM	ESTIMATED CONSTRUCTION COST			
		QUANTITY	UNIT	UNIT COST	TOTAL
<b>Construction Costs</b>					
1	MOBILIZATION	1	L.S.	\$16,500.00	\$16,500.00
2	CONSTRUCTION SURVEYING	1	L.S.	\$4,000.00	\$4,000.00
3	PROJECT TEMPORARY TRAFFIC CONTROL	1	L.S.	\$2,000.00	\$2,000.00
4	TEMPORARY STREAM DIVERSION AND DEWATERING	1	L.S.	\$10,000.00	\$10,000.00
5	DEFISHING LABOR	60	HR.	\$125.00	\$7,500.00
6	CLEARING AND GRUBBING	1	L.S.	\$4,500.00	\$4,500.00
7	REMOVAL OF STRUCTURE AND OBSTRUCTION	1	L.S.	\$3,000.00	\$3,000.00
8	SHORING OR ADDITIONAL STRUCTURE EXCAVATION CLASS A	1	L.S.	\$6,000.00	\$6,000.00
9	STRUCTURE EXCAVATION CLASS A INCL. HAUL (BOX CULVERT )	300	C.Y.	\$15.00	\$4,500.00
10	STRUCTURE EXCAVATION CLASS B INCL. HAUL (CHANNEL & UTILITY EXCAVATION)	125	C.Y.	\$15.00	\$1,875.00
11	CONSTRUCTION GEOTEXTILE FOR SEPERATION (BOX CULVERT)	100	S.Y.	\$10.00	\$1,000.00
12	CONSTRUCTION GEOTEXTILE FOR DITCH LINING (JUTE MATTING)	130	S.Y.	\$10.00	\$1,300.00
13	POTHOLE EXISTING UTILITY	10	EA.	\$350.00	\$3,500.00
14	STREAMBED SEDIMENT	120	TON	\$90.00	\$10,800.00
15	GRAVEL BASE	123	TON	\$20.00	\$2,460.00
16	GRAVEL BACKFILL FOR PIPE ZONE BEDDING	25	TON	\$25.00	\$625.00
17	CRUSHED SURFACING TOP COURSE	20	TON	\$60.00	\$1,200.00
18	PERMEABLE BALLAST	120	TON	\$60.00	\$7,200.00
19	4x8 QUARRY SPALLS	100	TON	\$70.00	\$7,000.00
20	HEAVY LOOSE RIP RAP	35	TON	\$85.00	\$2,975.00
21	TWO MAN ROCK	15	EA.	\$300.00	\$4,500.00
22	HMA CL 1/2-IN PG 64-22	20	TON	\$200.00	\$4,000.00
23	8X4 BOX CULVERT STRUCTURE	48	L.F.	\$1,380.00	\$66,240.00
24	SOLID WALL PVC SDR 35 SANITARY SEWER PIPE, 8-INCH DIAMETER	27	L.F.	\$35.00	\$945.00
25	DUCTILE IRON SANITARY SEWER SLEEVE, 12-INCH DIAMETER	27	L.F.	\$90.00	\$2,430.00
26	DUCTILE IRON WATERMAIN, 6-INCH DIAMETER	27	L.F.	\$85.00	\$2,295.00
27	WATERMAIN TESTING, COMPLETE	1	L.S.	\$4,000.00	\$4,000.00
28	SEWERMAIN DIVERSION	1	L.S.	\$6,000.00	\$6,000.00
29	MANHOLE 48 IN. DIAM. TYPE II	1	EA.	\$7,000.00	\$7,000.00
30	TOPSOIL CLASS A	20	C.Y.	\$65.00	\$1,300.00
31	SELECTED PLANTINGS	1	L.S.	\$6,500.00	\$6,500.00
32	TEMPORARY EROSION AND SEDIMENT CONTROL	1	L.S.	\$5,000.00	\$5,000.00
33	WOOD CHIP MULCH	30	C.Y.	\$40.00	\$1,200.00
	<i>Subtotal</i>				\$209,345.00
	<i>Tax @ 8.5%</i>				\$17,794.33
	<i>Construction Cost Total</i>				\$227,139.33
	<i>10% Contingency</i>				\$22,713.93
<b>PROJECT TOTAL</b>					<b>\$249,853.26</b>

Assuming Road Closure Only - No Flaggers



## Tyler Andrews

---

**From:** Bill Hunter <bill.hunter@lwwsd.org>  
**Sent:** Monday, August 17, 2020 4:42 PM  
**To:** Tyler Andrews  
**Cc:** Joe Acla (gm@suddenvalley.com); Justin Clary  
**Subject:** RE: SVCA - 2021 Box Culvert Design Projects  
**Attachments:** Task Order 2020-008-SVCA Culverts Plan Review.doc; Engineering Fee Estimate-TO#8\_2020 Rates.pdf

Hi Tyler,

Estimated District labor and consultant resources is in the range of \$26k. I have attached the District's General Engineering consultant's estimate that outlines assumptions. The District staff administration cost estimate of \$3.5k is based on the previous SVCA Area Z Fire Hydrant cost.

District's consultant estimate:	\$22,712
<u>District staff administration:</u>	<u>\$ 3,500</u>
Estimate Total	\$26,212

The actual amount will depend on plan review/coordination, duration of construction, unforeseen challenges discovered during excavation, and coordination between contractor and District's consultant for field observations.

Bill Hunter, P.E. | Assistant General Manager / District Engineer



**LAKE WHATCOM WATER & SEWER DISTRICT**

1220 Lakeway Drive  
Bellingham, WA 98229

8am – 5pm, Monday – Thursday  
(360) 734-9224, Fax: (360) 738-8250  
[www.lwwsd.org](http://www.lwwsd.org)

Email from this address is subject to public disclosure pursuant to RCW 42.56.

---

**From:** Tyler Andrews [mailto:tylera@pnwcivil.com]  
**Sent:** Thursday, June 18, 2020 7:51 PM  
**To:** Bill Hunter  
**Subject:** SVCA - 2021 Box Culvert Design Projects

Hi Bill,

Since we spoke over a month ago we've gone thru updating the drawings to basically be a final edition. Per our conversation regarding the sewer being clay pipe in 6' sticks I had the engineer include setting a new manhole at each location with new sewer pipe with a casing below the box culverts. Waterline is still as we discussed with a stove pipe detail. Since we spoke I received back the Geotech report as well, and the cross section shown reflects what will be our excavation limits for depth. Please let me know if you have any questions on the updated drawings. Both of these

projects have been pushed to construction in 2021. All permitting will be finalized in the near future, but the decision has been made to shift construction 1 season.

As we discussed attached is the DEA application, but unsigned. If you can provide a budget for the cost associated with LWWS's involvement in this I will then get Joe's signature on it to finalize it. Before signing we just want to have an idea of what the fees will be as we discussed.

Thanks,  
Tyler

Tyler Andrews  
PNW Civil, Inc.  
PO Box 30498  
Bellingham, WA 98228  
360-739-2072

**LAKE WHATCOM WATER AND SEWER DISTRICT**

**SVCA DEA - Utility Relocation**

Prepared by: M. Mankamy, P.E., Wilson Engineering LLC  
 Prepared for: Bill Hunter, P.E., LWWS District Engineer/ Assistant General Manager  
 Proposal No.: 2020-001; Task Order 008  
 Date: July 1, 2020

Task Description		Principal Engineer	Senior CAD Design Technician	
Rate (\$/hr) =	L.S.	\$170	\$107	
<b>Task 1: Project Management / Meetings / Coordination</b>				
Track and report progress & expenditures monthly		4		\$ 680
Project Coordination with District		12	4	\$ 2,468
<b>Sub-Total</b>	<b>\$ -</b>	<b>16</b>	<b>4</b>	<b>\$ 3,148</b>
<b>Task 2: Plan Review</b>				
1 - Initial Plan Review and Comment/Response Letter		8	12	\$ 2,644
2 - Revised Plan Review and Comment/Response Letter		4	4	\$ 1,108
3 - Revised Plan Review and Approval Letter		2	2	\$ 554
<b>Sub-Total</b>	<b>\$ -</b>	<b>14</b>	<b>18</b>	<b>\$ 4,306</b>
<b>Task 3: Construction Inspection</b>				
1 - Prepare for / Attend Pre-construction meeting		4	4	\$ 1,108
2 - Inspection - on-site (assume 80 hours)			80	\$ 8,560
3 - Inspection - daily reports			16	\$ 1,712
<b>Sub-Total</b>	<b>\$ -</b>	<b>4</b>	<b>100</b>	<b>\$ 11,380</b>
<b>Task 4: Project Closeout</b>				
1 - Review Record Drawings (assume one revision)		4	8	\$ 1,536
2 - Prepare Bill of Sale		6	4	\$ 1,448
3 - Prepare Construction Completion Report		4	2	\$ 894
<b>Sub-Total</b>	<b>\$ -</b>	<b>14</b>	<b>14</b>	<b>\$ 3,878</b>
<b>Direct Expenses</b>				\$ -
<b>Project Total</b>	<b>\$ -</b>	<b>48</b>	<b>136</b>	<b>\$ 22,712</b>

Assumptions:

1. District will provide Project Administration and correspondence with SVCA.
2. Third plan submittal will meet all District requirements to be approved.
3. Second Record Drawing submittal will meet all District requirements to be approved.

Sudden Valley Community Association  
**2021 Culvert Replacements from 2020**  
 PNW Estimate - Bid Package, Permitting, and Construction Management

**Culvert 315 - Construction Management**

Task	Description	Hours	Estimated Cost
Construction Management			
	Contract issuance to contractor, and preconstruction coordination.	8	
	Construction observation - Part time observation.	100	
	Construction closeout with contractor, permit agencies, and utility companies.	16	
	<b>Total Estimated Construction Management Hours</b>	124	<b>\$ 16,740.00</b>



**Sudden Valley Community Association**  
360-734-6430  
4 Clubhouse Circle Bellingham, WA 98229  
www.suddenvalley.com

## CAPITAL REQUEST MEMO

**To: Sudden Valley Community Association Board of Directors**  
**From: Jo Anne Jensen, General Manager**  
**Date: April 13, 2023**  
**Subject: Capital Request – Irrigation System Pump Controller Replacement**

---

### **Purpose**

To request approval for purchase and installation of a new irrigation system pump controller (PLC).

### **Background**

The golf course irrigation system was extensively renovated in 1994 with the addition of a new piping and control system. This work included an upgrade to the pump station located at hole 17 where a new PLC and Variable Frequency Drive system was installed to operate the pumps for the golf course. Used heavily between June and October, these heavy-duty pumps move about 20 million gallons of water annually through the network of pipes and pumping stations that traverse the 150 acres occupied by the golf course.

The PLC for the irrigation system coordinates the operation of the individual components and tracks overall performance. This spring, when Turf Care tried to charge the irrigation system, there was no feedback from the pump station monitoring devices and the pumps were working at a low rpm. Upon investigation, it was determined that the electronic monitoring system had failed. Simply stated, the existing PLC, installed in 2014, no longer works and needs to be replaced. The industry average life span of a pump station PLC is 10 years of reliable service. Without the electronics retrofit installed, the pump station will operate at an undesirable low speed. This would lead to the pumps overheating and ineffective irrigation throughout the golf course.

### **Proposal**

There is only one remaining company, McDonald and Sons Ventures, LLC, that services golf course irrigation systems in Washington state. This organization evaluated our system and proposed three different options (estimate attached). After consideration, SVCA selected the Watertronics option because it is compatible with our current system needs and is the only one of the three options that comes with electronic butterfly valves (EBVs). This feature enables a “slow start” which protects pipes by eliminating an initial high-pressure burst of water into the system.

The expected useful life of the new Watertronics PLC is 10 years. Because the replacement of the PLC was not planned for 2023, we propose to defer a portion of the maintenance of the Turf Care building which was planned for 2023 until 2024 to provide the funds for this work.

**Request**

Request that the SVCA Board of Directors approve \$43,671.32 for the purchase and installation of a new PLC for the Golf Course irrigation system.

**Motion**

Move that the SVCA Board of Directors approve a not to exceed amount of \$43,671.21 from CRRRF funds previously allocated for the maintenance of the Turf Care building for the purchase and installation of a new PLC for the golf course irrigation system.

**Board of Directors Approval**

Approved: \_\_\_\_\_ Not Approved: \_\_\_\_\_ SVCA Board of Directors

# McDonald & Sons Ventures LLC

# JOB QUOTE

8124 61st Ave Ct. E  
Puyallup, Washington 98371

Phone Will (253) 209-1473 Andrew (206) 775-9563 Fax (253) 302-5490

Email: will@mcdonaldsonslc.com andrew@mcdonaldsonslc.com

**DATE:** 3/29/2023

**QUOTE #** SV 3-23B

**Bill To:** Sudden Valley Golf Club  
4 Clubhouse Circle  
Bellingham, Washington 98229

**Ship To:** Same Address

**Comments or Special Instructions:** New PLC Quotes

SALESPERSON	P.O. NUMBER	SHIP DATE	SHIP VIA	F.O.B. POINT	TERMS
Will			our truck		Due on receipt

QUANTITY	DESCRIPTION	UNIT PRICE	AMOUNT
1.0	Flowtronex Retrofit Kit / with monitoring	56,467.00	\$ -
	Sales tax @ 8.60%		56,467.00
	<b>Total Installed Cost</b>		4,856.16
			61,323.16
1.0	Watertronics retrofit kit / with monitoring	36,842.00	36,842.00
	Sales tax @ 8.60%		3,168.41
	<b>Total Installed Cost</b>		40,010.41
1.0	Precision Pump retrofit kit / with monitoring	25,816.00	25,816.00
	Sales tax @ 8.60%		2,220.18
	<b>Total Installed Cost</b>		28,036.18
SUBTOTAL			
TAX RATE			
SALES TAX			-
SHIPPING & HANDLING			
<b>TOTAL</b>			\$ -

Make all checks payable to **McDonald & Sons Ventures LLC**

THANK YOU FOR YOUR BUSINESS!

# McDonald & Sons Ventures LLC

# JOB QUOTE

8124 61st Ave Ct. E  
Puyallup, Washington 98371

Phone Will (253) 209-1473 Andrew (206) 775-9563 Fax (253) 302-5490

Email: will@mcdonaldsonslc.com andrew@mcdonaldsonslc.com

**DATE:** 4/2/2023

**QUOTE #** SVGC

**Bill To:** Sudden Valley  
4 Clubhouse Circle  
Bellingham, Washington 98229

**Ship To:** Same Address

**Comments or Special Instructions:** Quote for new PLC and Lake Fill Controls

SALESPERSON	P.O. NUMBER	SHIP DATE	SHIP VIA	F.O.B. POINT	TERMS
Will			our truck		Due on receipt

QUANTITY	DESCRIPTION	UNIT PRICE	AMOUNT
	<b>Main Station PLC</b>		\$ -
1.0	Watertronics retrofit kit - w/5yrs monitoring	18,830.00	18,830.00
2.0	Electronic Butterfly Valves	3,356.00	6,712.00
1.0	Watervision Cellular Monitoring - 5yr Subscript.	6,900.00	6,900.00
30.0	Labor	135.00	4,050.00
2.0	Per diem	175.00	350.00
	<b>Lake Fill Station</b>		
1.0	40hp Soft Start Motor Controller	1,771.00	1,771.00
1.0	4" Pipe Spool to replace Cla-Valve	250.00	250.00
10.0	Labor including travel	135.00	1,350.00
	<b>SUBTOTAL</b>		\$ 40,213.00
	<b>TAX RATE</b>		8.60%
	<b>SALES TAX</b>		3,458.32
	<b>SHIPPING &amp; HANDLING</b>		
	<b>TOTAL</b>		\$ 43,671.32

Make all checks payable to **McDonald & Sons Ventures LLC**

THANK YOU FOR YOUR BUSINESS!



**Sudden Valley Community Association**  
 360-734-6430  
 4 Clubhouse Circle Bellingham, WA 98229  
 www.suddenvalley.com

**CAPITAL REQUEST MEMO**

**To: Sudden Valley Community Association Board of Directors**  
**From: Jo Anne Jensen, General Manager**  
**Date: April 13, 2023**  
**Subject: Capital Request – Firewise Funding**

---

**Purpose**

To request approval for funding annual Firewise and roadside cleanup activities.

**Background**

Removing vegetation reduces the risk of fire, keeps ditches and culverts clear, and improves the appearance of properties. Beginning last year, the Firewise program was expanded to include the cleanup of roadsides throughout the community. Each area of the Association is assigned a schedule for picking up debris, residents bring it to the roadside, and Maintenance picks it up and chips it. In past years, allocations from UDR were used to pay for this activity. Beginning in 2024, this activity will become an operational line item.

**Proposal**

In 2022, Firewise was completed with a four-person crew, and took place over a five-week time frame. Expenditures included renting a large capacity woodchipper to facilitate chipping a large amount of material over an extended period. This approach worked well, and we propose to repeat it in 2023.

**Summary of Costs:**

<b>Category</b>	<b>Quantity</b>	<b>Cost</b>	<b>Extension</b>
Supervisor	40 hrs	\$ 50	\$ 2,000
Labor	800 hrs	\$ 32	\$ 25,600
Chipper Rental	1	\$ 4,000	\$ 4,000
<b>Total</b>			<b>\$ 31,600</b>

**Request**

Request that an allocation of \$ 31,600 be made from UDR to cover the costs of Firewise in 2023.

**Motion**

Move that an allocation of not to exceed \$ 31,600 be made from UDR to cover the costs of Firewise, as proposed, in 2023.

**Board of Directors Approval**

Approved: \_\_\_\_\_ Not Approved: \_\_\_\_\_ SVCA Board of Directors



**Sudden Valley Community Association**  
 360-734-6430  
 4 Clubhouse Circle Bellingham, WA 98229  
 www.suddenvalley.com

**APPROVAL REQUEST MEMO**

**To: Sudden Valley Community Association Board of Directors**  
**From: Jo Anne Jensen, General Manager**  
**Date: April 13, 2023**  
**Subject: Approval Request – Pool Services Agreement**

---

**Purpose**

To request approval for purchase of the 2023 Pool Services Agreement with Cesco Solutions.

**Background**

Cesco Solutions has provided chemicals and pool services to SVCA for many years. They have done a good job maintaining the health and safety of our pools. To obtain a permit for operating a public pool, a Certified Pool Operator must be under contract and Cesco satisfies that requirement.

**Proposal**

The proposed 2023 pool services agreement is similar to the agreement approved in 2022. The table below shows the breakout of costs by category and shows a comparison to the 2022 costs.

<b>Category</b>	<b>2022 Cost</b>	<b>2023 Cost</b>
Chemicals	\$866.76	\$1,282.81
Labor (6 hrs/wk)	\$672	\$825
Pool Controller System Rental	\$50	\$50
Per week Cost (w/tax)	\$1,725.50	\$2,343.38
Start up chemicals		\$3,536.96
Start up labor		\$4,000.00
Total (18 week season)	\$47,142.98	\$49,717.80

**Request**

Request that the SVCA Board of Directors approve the 2023 pool services agreement with Cesco Solutions.

**Motion**

Move that the SVCA Board of Directors approve the 2023 pool services agreement with Cesco Solutions.

**Board of Directors Approval**

Approved: \_\_\_\_\_ Not Approved: \_\_\_\_\_ SVCA Board of Directors

□

All materials are guaranteed to be as specified. All work to be completed in a professional manner according to standard industry practices. Any alteration or deviation from above specifications involving extra costs will be executed only upon written orders and will become an extra charge over and above the estimate. This document represents notice of intent to lien upon default of payment in full within 30 days of completion. All agreements are contingent upon reasonable access, strikes, accidents, or other delays beyond our control. This proposal is subject to acceptance within 30 days and is void thereafter at the option of the undersigned.

**ACCEPTANCE OF PROPOSAL**

The above prices, specifications and conditions are hereby accepted. You are authorized to do the work as specified. Payment will be made as outlined above.

Customer Signature

DATE \_\_\_\_\_



**Service and Lease Agreement**

**Between** Sudden Valley Community Association and Cesco Solutions

2650 Lake Lousie Rd  
Bellingham, WA 98225

2227 Midway Lane  
Bellingham, WA 98226

**PROJECT LOCATION AND DESCRIPTION:**  
Weekly Service Contract for two pools at Sudden Valley. Includes: Pool Controller lease for large pool; Service, Maintenance and Chemicals (2023 summer season) for both pools.

**THIS SERVICE AND EQUIPMENT RENTAL AGREEMENT made this 3/24/2023 between:  
Cesco Solutions and Sudden Valley Community Association**

Equipment Model(s)	Description	Quantity
Pool Chemical Controller	Includes Mounting Board with Pressure Safety Switch and Chemical Pumps for liquid chlorine sanitizer and Muriatic acid pH buffer. Flow cell with ORP & pH Probes for control of Pool and Spa.	1

**WE HEREBY SUBMIT ESTIMATE AND SPECIFICATIONS FOR THE FOLLOWING:**

**Term:** 2023 Swimming season from when Sudden Valley would like to start usually starting Mid-May to right after Labor Day September 4<sup>th</sup>. (This is flexible)

**Estimated weekly chemical costs:** \$1282.81.

**Estimated weekly labor** \$825.

**Pool controller lease** \$50 per week

=Total \$2157.81 per week at 8.6% tax \$185.57 **Approximate total weekly running cost with Tax \$2343.38** Contract will be invoiced weekly until the end of the contract term.

**Estimated Startup Chemicals** \$3536.96 plus 8.6%tax \$304.18= **total \$3841.13 with Tax**

**Estimated Startup Labor** if Cesco is to do most of the Startup pool cleaning labor \$5500 plus 8.6% tax \$473=**Total \$5973 with tax** Some of this labor can be offset by Sudden Valley employees doing most of the cleaning.

- This weekly estimated total is broken down with 6 hours labor, pool controller lease and estimated chemical usage of chemicals used in a week.
- Chemical usage is directly related to weather and bather load. Sudden Valley will be billed for actual chemicals used (not estimated). Chemical costs maybe more or less than estimated and invoiced weekly for the labor and pool controller lease. I suspect that we will use less chemicals this year due to the pool repairs that were made last fall.
- Cesco will provide and maintain a lease Pool Chemical Controller System for Sudden Valley's large pool (Cesco Solutions to maintain ownership of the Pool Controller system). Sudden Valley owns a controller for the small (Adult) pool. It's in place and will need to be tuned up with new squeeze tubes. The cost for that will probably be about \$200 for that if everything is in working order, worse case about \$500 if the ph and orp sensors are bad.
- Chemistry will be set and maintained by Cesco and monitored by Sudden Valley.
- Sudden Valley is responsible for testing and recording daily pool chemical readings as required by law.
- Filter system cleanings and backwashes will be performed by a trained Cesco employee.
- Cesco will visit the pools 2 – 3 times a week during normal business hours (Monday – Friday, 7am to 5pm) to check on the pool systems/ chemistry and maintain levels. Additional hours above 6 hours per week (for issues) will be billed at Cesco's service rate of \$137.50. After hours on-site support will be billed at Cesco's after hour service rates \$206.25 hr. Phone support is free.
- Cesco will provide employee training both initial and on-going so that Sudden Valley employees can manage the day-to-day operations of vacuuming, cleaning, and performing daily pool chemistry tests.
- Accidental fecal releases will be the responsibility of Sudden Valley.
- Parts & Labor due to equipment failures/repairs are not included and will be billed at normal Cesco rates (this excludes all repairs to the large pool controller supplied by Cesco, which will be the responsibility of Cesco to repair or replace at no cost to Sudden Valley. Sudden Valley owns the adult pool controller.



**Sudden Valley Community Association**  
360-734-6430  
4 Clubhouse Circle Bellingham, WA 98229  
www.suddenvalley.com

## CAPITAL REQUEST MEMO

**To: Sudden Valley Community Association Board of Directors**  
**From: Jo Anne Jensen, General Manager**  
**Date: April 13, 2023**  
**Subject: Capital Request – Welcome Center HVAC**

---

### Purpose

To request approval for purchase of an HVAC system for the Welcome Center.

### Background

The Welcome Center is heated by electric wall heaters that operate independently. There is no cooling system currently installed. For the comfort of both staff and guests and to ensure temperatures remain at an appropriate and consistent level, an HVAC system is needed.

### Proposal

In the fall of 2022, three local HVAC contractors were asked to provide recommendations for how best to heat and cool the building. When asked to update their bids in 2023, only one of these contractors responded, and has not yet updated their quote. A fourth contractor, Marr's Heating and Air Conditioning, was brought in to provide an estimate. While all of the contractors suggested installing heat pumps, the recommendations differed on the type and number of units needed. A summary of the quotes provided is shown in the table below:

<b>Contractor</b>	<b>Date of Estimate</b>	<b>Pre-Tax</b>	<b>Total</b>
Marr's Heating and Air Conditioning	4/5/2023	\$ 44,524	\$ 48,404
Andgar Mechanical	8/26/2022	\$ 39,381	\$ 42,768
Lynden Sheet Metal	10/6/2022	\$ 39,380	\$ 43,255
Barron Heating and Air Conditioning	9/15/2022	\$ 52,388	\$ 56,894

I recommend going forward with Marr's Heating and Air Conditioning. Their estimate is more thorough and comprehensive than the others we received. A detailed analysis of the structure was completed, with an overview provided of why the system they recommend is the best option over alternative methods. Additionally, their pricing includes elements of work that the lowest bidder did not, such as electrical work. Marr's heating also includes a lifetime workmanship warranty as well as a one-year satisfaction guarantee. The estimate and supplemental information that Marr's Heating provided make them the preferred option, even if the other vendors had updated and honored their original quotes.

In the 2023 Capital Budget, \$40,000 was allocated to the replacement of a portion of the HVAC system serving the Clubhouse. Repairs were made in 2022 to the Clubhouse HVAC system and it

is functioning appropriately. I recommend deferring the Clubhouse HVAC repair and using that budgeted amount to fund this project.

**Request**

Request that the SVCA Board of Directors approve the allocation of \$48,404 from CRRRF for the installation of an HVAC system in the Welcome Center.

**Motion**

Move that the SVCA Board of Directors approve the allocation of \$48,404 from CRRF for the installation of an HVAC system in the Welcome Center.

**Board of Directors Approval**

Approved: \_\_\_\_\_ Not Approved: \_\_\_\_\_ SVCA Board of Directors



**BILL TO**

Mike Brock  
 1850 Lake Whatcom Boulevard  
 Bellingham, WA 98229 USA

<b>ESTIMATE</b> 41707366	<b>ESTIMATE DATE</b> Apr 05, 2023
-----------------------------	--------------------------------------

**JOB ADDRESS**

Mike Brock  
 1850 Lake Whatcom Boulevard  
 Bellingham, WA 98229 USA

**Job:** 41385385

**ESTIMATE DETAILS**

- Bosch Heat Pump & Air Handler BOVA15 w/ Ductwork System:
- Remove and recycle existing equipment
  - Set new equipment and adapt with custom sheet metal fittings as needed
  - Seal new duct connections per code and company standards
  - Run new copper refrigerant line set per company standards
  - Refrigerant lines shall be brazed with nitrogen purge
  - Refrigerant lines shall be pressure tested at manufacturer recommended PSI
  - Refrigerant lines shall be evacuated into a deep vacuum below 300 microns
  - Evacuation of refrigerant lines shall pass decay rate test
  - All holes drilled in home shall be sealed with proper sealant or weatherproof fittings
  - Outdoor unit location is to be prepped with gravel before cement pad is set
  - New Heat Pump Thermostat shall be installed and configured including lockout settings
  - Multi-point digital start-up checklist shall be performed including airflow and subcooling
  - Job site shall be cleaned to Marr's Heating Standards
  - Free Tune-up performed 1 year from installation date free of charge

\*\*CASH, CARD, CHECK or our 18 MONTH FINANCING will REMOVE 8.5% OFF TOTAL AMOUNT SHOWN\*\*

\*\*This system is designed to heat/cool the offices on the North side of the building\*\*

TASK	DESCRIPTION	QTY	PRICE	TOTAL
1	Refrigerant Safety caps (anti huff)	1.00	\$0.00	\$0.00
2	Condensate drain overflow safety lockout (Prevents water damage from clogged condensate drain line)	1.00	\$0.00	\$0.00
3	Titan wall piping penetration system	1.00	\$0.00	\$0.00

4	Perform preventative Maintenance one year after installation	1.00	\$0.00	\$0.00
5	Surge protector	1.00	\$0.00	\$0.00
6	<b>Honeywell Prestige</b> Heat pump thermostat with outdoor sensor is included with system <a href="#">Brochure-click here</a>	1.00	\$0.00	\$0.00
7	Class B Electrical permit	1.00	\$36.00	\$36.00
8	Basic permit city/county single unit	1.00	\$126.00	\$126.00
9	<b>Honeywell F-100 Media air filter and cabinet</b> <a href="#">Brochure-click here</a>	1.00	\$420.00	\$420.00
10	Electrical - Connect new equipment to existing panel	1.00	\$1,920.00	\$1,920.00
11	Difficult attic 25 ft return duct up to 18 in. including elbows and upsizing	1.00	\$2,643.00	\$2,643.00
12	Return air box fabricate and cut in (price is per cut-in)	1.00	\$694.00	\$694.00
13	Steel insulated trunk up to 18 in. per section	2.00	\$966.00	\$1,932.00
14	Boot cut in and install up to 4-14 boots, hardwood, carpet, laminate,drywall (price is per boot)	8.00	\$169.00	\$1,352.00
15	25ft Flex run up to 9 in (per run)	8.00	\$591.00	\$4,728.00
16	<b>Bosch IDS LITE 3 Ton Heat Pump System:</b> IDS Inverter Model group: BOVA15 15 Seer Bosch Air handler Model group: BVA15 Psc single stage standard efficiency fan <b>Warranty:</b> 1 yr. labor 10 yr. parts (see Warranty terms) <a href="#">Brochure-click here Bosch Heat Pumps</a>	1.00	\$16,627.00	\$16,627.00
17	Discount per Caleb if accepted by 4/14	1.00	\$-1,800.00	\$-1,800.00
18	<b>Cash/card or optional Financing promo: 0% Down, 0% APR for 18 Months</b> on approved credit <a href="#">Click to apply for financing. Discount is already applied below.</a>	1.00	\$0.00	\$0.00

<b>POTENTIAL SAVINGS</b>	\$0.00
<b>SUB-TOTAL</b>	\$28,678.00
<b>TAX</b>	\$2,466.31
<b>TOTAL</b>	\$31,144.31

Thank you for choosing Marr's Heating & Air Conditioning

**CUSTOMER AUTHORIZATION**

THIS IS AN ESTIMATE, NOT A CONTRACT FOR SERVICES. The summary [above] is furnished by Marr's Heating & Air Conditioning as a good faith estimate of work to be performed at Mike Brock[the location described above] and is based on our evaluation and does not include material price increases or additional labor and materials which may be required should unforeseen problems arise after the work has started. I understand that the final cost of the work may differ from the estimate, perhaps materially. THIS IS NOT A GUARANTEE OF THE FINAL PRICE OF WORK TO BE PERFORMED. I agree to the estimate and authorize [the contractor] to perform the work as summarized and on these estimated terms, and I agree to

pay the full amount for all work performed.

Sign here

Date

---



**BILL TO**

Mike Brock  
 1850 Lake Whatcom Boulevard  
 Bellingham, WA 98229 USA

<b>ESTIMATE</b> 41707221	<b>ESTIMATE DATE</b> Apr 05, 2023
-----------------------------	--------------------------------------

**JOB ADDRESS**

Mike Brock  
 1850 Lake Whatcom Boulevard  
 Bellingham, WA 98229 USA

**Job:** 41385385

**ESTIMATE DETAILS**

- Mitsubishi 3 Headed Ductless Heat Pump System (Scope of work): -Outdoor unit location is to be prepped with gravel before cement pad is set
- Outdoor unit will be set on risers per code and company standards
  - Outdoor unit will have seismic straps per code and company standards
  - Indoor units shall be secured and mounted properly per company standards
  - Run new Insulated copper refrigerant line set per company standards
  - Refrigerant lines shall be flared and torqued to manufacturer specifications
  - Refrigerant lines shall be pressure tested at manufacturer recommended PSI
  - Refrigerant lines shall be evacuated into a deep vacuum below 300 microns
  - Evacuation of refrigerant lines shall pass decay rate test
  - Paintable Refrigerant line cover shall be installed per company standards
  - All holes drilled in home shall be sealed with proper sealant or weatherproof fittings
  - Multi-point digital start-up checklist shall be performed
  - Job site shall be cleaned to Marr's Heating Standards
  - Surge Protection shall be installed per company standards
  - Free Tune-up performed 1 year from installation date free of charge

\*\*CASH, CARD, CHECK or our 18 MONTH FINANCING will REMOVE 8.5% OFF TOTAL AMOUNT SHOWN\*\*

\*\*This system is designed to heat/cool the offices on the South side of the building and the second story break room\*\*

TASK	DESCRIPTION	QTY	PRICE	TOTAL
1	Refrigerant Safety caps (anti huff)	1.00	\$0.00	\$0.00
2	Perform preventative Maintenance one year after installation	1.00	\$0.00	\$0.00
3	: Surge protector	1.00	\$0.00	\$0.00

4	Electrical - Connect new equipment to existing panel	1.00	\$1,420.00	\$1,420.00
5	<b>Mitsubishi</b> GI Series head Model: MSZGL18NA-U1 18,000 btu <b>Warranty:</b> 1 yr. labor 12 yr. parts (see Warranty terms)	1.00	\$2,425.00	\$2,425.00
6	<b>Mitsubishi</b> GI Series head Model: MSZGL06NA-U1 6,000 btu <b>Warranty:</b> 1 yr. labor 12 yr. parts (see Warranty terms)	2.00	\$1,925.00	\$3,850.00
7	<b>Mitsubishi</b> GI Series head Model: MSZGL09NA-U1 9,000 btu 9,000 btu <b>Warranty:</b> 1 yr. labor 12 yr. parts (see Warranty terms)	1.00	\$1,965.00	\$1,965.00
8	<b>Mitsubishi</b> Multi-zone Outdoor unit Model: MXZ4C36NA2-U1 36,000 btu <b>Warranty:</b> 1 yr. labor 12 yr. parts (see Warranty terms) <a href="#">Brochure-click here</a>	1.00	\$7,272.00	\$7,272.00
9	Speedichannel Lineset cover	2.00	\$507.00	\$1,014.00
10	Discount per Caleb if accepted by 4/14	1.00	\$-1,500.00	\$-1,500.00
11	Instant PSE Midstream Cash Rebate	1.00	\$-600.00	\$-600.00
12	<b>Cash/card or optional Financing promo: 0% Down, 0% APR for 18 Months</b> on approved credit <a href="#">Click to apply for financing. Discount is already applied below.</a>	1.00	\$0.00	\$0.00

<b>POTENTIAL SAVINGS</b>	\$0.00
<b>SUB-TOTAL</b>	\$15,846.00
<b>TAX</b>	\$1,414.36
<b>TOTAL</b>	\$17,260.36

Thank you for choosing Marr's Heating & Air Conditioning

**CUSTOMER AUTHORIZATION**

THIS IS AN ESTIMATE, NOT A CONTRACT FOR SERVICES. The summary [above] is furnished by Marr's Heating & Air Conditioning as a good faith estimate of work to be performed at Mike Brock [the location described above] and is based on our evaluation and does not include material price increases or additional labor and materials which may be required should unforeseen problems arise after the work has started. I understand that the final cost of the work may differ from the estimate, perhaps materially. THIS IS NOT A GUARANTEE OF THE FINAL PRICE OF WORK TO BE PERFORMED. I agree to the estimate and authorize [the contractor] to perform the work as summarized and on these estimated terms, and I agree to pay the full amount for all work performed.

Sign here

Date



# Proposal

6920 Salashan Pkwy, A-102  
 PO Box 2708  
 Ferndale WA 98248  
 Email: [kevinw@andgar.com](mailto:kevinw@andgar.com)

Office: (360) 366-9900  
 Fax: (360) 366-5800  
<http://www.andgar.com>

To: Sudden Valley Maintenance	Phone: 360-778-2223	Date: 8-26-22
	Project: Sun Mark Bldg HVAC Upgrades 1850 Lake Whatcom Blvd Bellingham, WA	
Attention: Mike Brock ( <a href="mailto:mike.brock@suddenvalley.com">mike.brock@suddenvalley.com</a> )		

**Base Bid – HVAC**

Provide and install:

- 1 each Daikin VRVs (or equal), 4-Ton, 16-SEER, 208/230-Volt, 1-Phase, outdoor heat pump
- 1 each Daikin VRVs (or equal) 4-ton, heat pump, indoor air handler. Note: air handler will be located in the 1<sup>st</sup> floor closet
- 1 each Daikin VRVs (or equal), 2.5-Ton, 16-SEER, 208/230-Volt, 1-Phase, outdoor heat pump (Multi Zone)
- 1 each Daikin 18-MBH, wall mounted indoor wall hung, heat pump, air handler will be mounted on the 2<sup>nd</sup> floor area
- 2 each Daikin 09-MBH, wall mounted indoor wall hung, heat pump, air handlers will be mounted in the South office areas
- Necessary controls for our scope of work
- Ductwork distribution per Andgar design
- Necessary line sets from outdoor units to indoor air handlers
- Necessary condensate drains
- Necessary grilles, registers & diffusers
- Start & test
- Permit
- One year warranty

**Exclusion:** Electrical line voltage, control wiring in conduit, P.E. Stamped Drawings, framing, equipment screening, fire rated soffits & chaseways, fire and/or fire smoke dampers, plumbing, painting, equipment walkways and/or platforms, work performed before 6:00-AM or after 6:00-PM, economizers, DOAS system(s) if required, Washington State Sales Tax

**Total Price for the Base bid is \$ 39,381.00**

**Terms as specified in contract or: Monthly Billings; Net 30 days from invoice**

Note: If non-contributory/primary named additional insured is required, our insurance company requires forms CG 0001 and CG 76 35.

All material is guaranteed to be as specified. All work to be completed in a professional manner according to standard practices. Any alteration or deviation from above specifications involving extra costs will be executed only upon written orders, and will become an extra charge over and above the estimate. All agreements contingent upon strikes, accidents or delays beyond our control. Owner to carry fire, tornado and other necessary insurance. Our workers are fully covered by Worker's Compensation Insurance.

Authorized Signature: \_\_\_\_\_ *Kevin G Wight* \_\_\_\_\_

Kevin G Wight

Note: This proposal may be withdrawn by us if not accepted within 45 days.

**Acceptance of Proposal** -The above prices, specifications and conditions are satisfactory and are hereby accepted. You are authorized to do the work as specified. Payment will be made as outlined above.

Signature: \_\_\_\_\_

Date of Acceptance: \_\_\_\_\_



# LYNDEN SHEET METAL, INC.

837 Evergreen Street, Lynden, WA 98264 (360)354-3991, (360) 354-1219 fax  
 www.lyndensheetmetal.com ~ Contractor's License #LYNDEI\*206DM

## PROPOSAL

PROPOSAL SUBMITTED TO: SUDDEN VALLEY COMMUNITY ASSOCIATION	PHONE: 360-778-9393	DATE: 10/6/2022
MAILING ADDRESS: 4 CLUBHOUSE CIR.	JOB DESCRIPTION: NEW HVAC - CENTRAL AND DUCTLESS	
CITY: BELLINGHAM	JOB SITE ADDRESS: 1850 LAKE WHATCOM BLVD	
CONTACT: MIKE	EMAIL:	

### Job Scope:

#### Central HVAC

- Provide and install an American Standard Silver 16 side discharge heat pump paired with an American Standard TEM 6 air handler. Install 10-ceiling registers in offices and common areas and 1- return air grille in common area by bathroom. Air handler and ducting to be installed in attic.

#### Included:

- Condensate drained to exterior.
- Exterior linesets installed in speedi channel.
- Outdoor unit set on pad on West side of building.
- Electrical wiring by licensed electricians.
- Electrical wiring permits.

Complete for above scope of work-----

### SYSTEM PRICE\*\*

\*\*Cash/ Check price. Sales tax will be added to this price.

\$22,965.00

#### Ductless Minisplit

- Provide and install a Mitsubishi multizone ductless heat pump with 3-zones on South side of the building supplying single upstairs room and lower rooms where central system cannot reach.

#### Included:

- Condensate drained to exterior.
- Exterior linesets installed in speedi channel.
- Outdoor unit set on pad on South side of building.
- Electrical wiring by licensed electricians.
- Electrical wiring permits.

Complete for above scope of work-----

\$ 16,865.00

#### Notes:

- Bid does not include anything not listed above.
- **Completion of work subject to Whatcom County mechanical permitting approval.**

**Current sales tax will be added all prices.**

Thank you for the opportunity to quote this project for you. If you have any questions, please don't hesitate to contact me. If you wish to proceed with the work, please circle chosen options, sign acceptance and return to us along with down payment.

Proposal Submitted by Andrew Rivas

This proposal may be withdrawn or prices updated if not accepted within 15 days of proposal date.

All material is guaranteed to be as specified. All work to be completed in a workmanlike manner. Any alteration from above specifications involving additional work will only be executed upon approval of the homeowner or contractor acting on their behalf & will be an extra cost above the estimate. Installation time frame is contingent on being able to obtain the necessary equipment and on previously committed projects and delays beyond our control. Our worker's are covered by Labor & Industries Insurance.

**ACCEPTANCE OF PROPOSAL** - The above prices, specifications and conditions are satisfactory and are hereby accepted. I authorized LSM to do the work. Payment will be made as outlined above. If I cancel the work, I realize I may be subject to a restocking fee on any ordered equipment.

Date \_\_\_\_\_ Signature \_\_\_\_\_



5100 Pacific Hwy #103, Ferndale WA 98248 Phone (800) 328-7774 (360) 676-1131 <https://barronheating.com>

**BILL TO**

Sudden Valley Community Association  
 4 Clubhouse Circle  
 Bellingham, WA 98229 USA

<b>ESTIMATE</b> 134900875	<b>ESTIMATE DATE</b> Sep 15, 2022
------------------------------	--------------------------------------

**JOB ADDRESS**

Sudden Valley Community Association  
 1850 Lake Whatcom Boulevard  
 Bellingham, WA 98229 USA

**Job:** 128517257

TASK	DESCRIPTION	QTY
*THX*	Thank you for choosing Barron Heating & Air Conditioning Our Mission: Improving Lives  <b>This Proposal Includes:</b> 1. Layout to determine location of new supply air ducts on the main floor 2. Installation of new heat pump and air handler for the north end main floor. 3. Install backup heat strip for air handler 4. Installation of new ductwork for air handler 5. Install a 3 head ductless system to condition the two southern end main floor offices and upstairs 6. All electrical service disconnects and hookups for new systems 7. Installation of new thermostat for heat pump system  <b>This Proposal Does Not Include:</b> 1. Cutting holes in tile for new supply air registers 2. Sheetrock repair 3. Painting of line-hide on exterior of building	1.00
HVAC Design Layout	Perform Layout to Confirm HVAC Design	1.00
6" Flex Supply Run Kit	Install 6" Insulated Flex Supply Air Duct	1.00
SDW-2001 (HIL.02.35)	Install Return Air Ductwork With a Capacity of 3.5 Tons	1.00
ACT-1195	Disclaimer: Holes in floor for new ductwork will need to be cut by other contractor prior to install. Layout to determine location of holes	1.00

ACT-1190	Disclaimer: Supplemental heat recommended for the coldest days, and for rooms/areas not conditioned with ductless	1.00
S-PERM200 (EIL.00.00)	Electrical Permit	1.00
S-PERM210 (HIL.00.00)	Low Voltage Permit	1.00
S-PERM100 (HIL.00.00)	Mechanical Permit	1.00
DV36FECC14	<b>Furnish and Install Daikin FIT Air Handler, Model: DV36FECC14</b>	1.00
	<ul style="list-style-type: none"> <li>• Air Handler - Variable Speed ECM Motor</li> <li>• Capacity: 3 Tons   Multi-Positional</li> <li>• 21"W x 53.5"H x 21"D</li> <li>• 15A   Lineset: 3/8"x7/8"</li> </ul>	
Daikin DV36FECC14		
HKSC10XC	<b>Furnish and Install Daikin Electric Strip Heat, Model: HKSC10XC</b>	1.00
	<ul style="list-style-type: none"> <li>• Daikin Electric Strip Heat</li> <li>• Capacity: 10kW   60A</li> </ul>	
Daikin HKSC10XC		
DZ17VSA361AA	<b>Furnish and Install Daikin FIT Heat Pump, Model: DZ17VSA361AA</b>	1.00
	<ul style="list-style-type: none"> <li>• Heat Pump Condensing Outdoor Unit - Modulating</li> <li>• Capacity: 3 Ton - 36K BTU</li> <li>• Efficiency Rating: 10 HSPF   62dBA</li> <li>• 36.625"W x 27.375"H x 13.75"D</li> <li>• 25A   Lineset: 3/8"x7/8"</li> </ul>	
Daikin DZ17VSA361AA		
DTST-CWBSA-NI-A-01	<b>Furnish and Install Daikin ONE+ Programmable Thermostat, Model: DTST-CWBSA-NI-A</b>	1.00
	<ul style="list-style-type: none"> <li>• WiFi</li> <li>• 4H/2C</li> </ul>	
Daikin DTST-CWBSA-NI-A		
3MXS24RMVJU	<b>Furnish and Install Daikin MXS Mini-Split Outdoor Unit, Model: 3MXS24RMVJU</b>	1.00
	<ul style="list-style-type: none"> <li>• Multi-Zone mini-split heat pump outdoor unit</li> <li>• Capacity: 2 Ton - 24k BTU   3 Port</li> <li>• Efficiency Rating: 12.5 HSPF   54dBA</li> <li>• 20A   Lineset: 1/4"x1/2"</li> </ul>	
Daikin 3MXS24RMVJU		

---

FTXS15LVJU     **Furnish and Install Daikin Indoor Unit, Model: FTXS15LVJU** 1.00

- Multi-Zone Wall Mount Indoor Unit
- Capacity: 1.25 Ton - 15k BTU | Multi-Zone
- 41.375"W x 13.375"H x 9.75"D
- Lineset: 1/4"x1/2"

Upstairs Unit

Daikin FTXS15LVJU

---

FTXS12LVJU     **Furnish and Install Daikin Indoor Unit, Model: FTXS12LVJU** 1.00

- Multi-Zone Wall Mount Indoor Unit
- Capacity: 1 Ton - 12k BTU | Multi-Zone
- 31.5"W x 11.625"H x 8.5"D
- Lineset: 1/4"x3/8"

Downstair Southeast Office

Daikin FTXS12LVJU

---

FTXS09LVJU     **Furnish and Install Daikin Indoor Unit, Model: FTXS09LVJU** 1.00

- Multi-Zone Wall Mount Indoor Unit
- Capacity: 3/4 Ton - 9k BTU | Multi-Zone
- 31.5"W x 11.625"H x 8.5"D
- Lineset: 1/4"x3/8"

Downstairs Southwest Office

Daikin FTXS09LVJU

<b>SUB-TOTAL</b>	\$52,388.13
<b>TAX</b>	\$4,505.38
<b>TOTAL</b>	<b>\$56,893.51</b>

You can pay your invoice online at <https://www.barronheating.com/make-payment> or [Pay Now](#).

Thank you for choosing Barron. We sincerely appreciate your business and hope that we exceeded your expectations. Please take a moment to [Review Us](https://www.youreview.us/barronheating) at <https://www.youreview.us/barronheating>.

**CUSTOMER AUTHORIZATION**

This invoice is agreed and acknowledged. Payment is due upon receipt. A service fee will be charged for any returned checks, and a financing charge of 1% per month shall be applied for overdue amounts.

**Did you know Barron offers a variety of energy solutions? From Energy Monitoring Services to Solar by Barron, our team can help you understand AND lower your energy costs.**

**Call our office or talk to your Barron technician for more information.**

Barron Authorized Signature: \_\_\_\_\_ Date: \_\_\_\_\_

The expiration date of Barron Heating's Contractor Registration No. BARROHA179D7: October 23, 2022.

Sign here

Date

---